

TRX

Assembly Guide

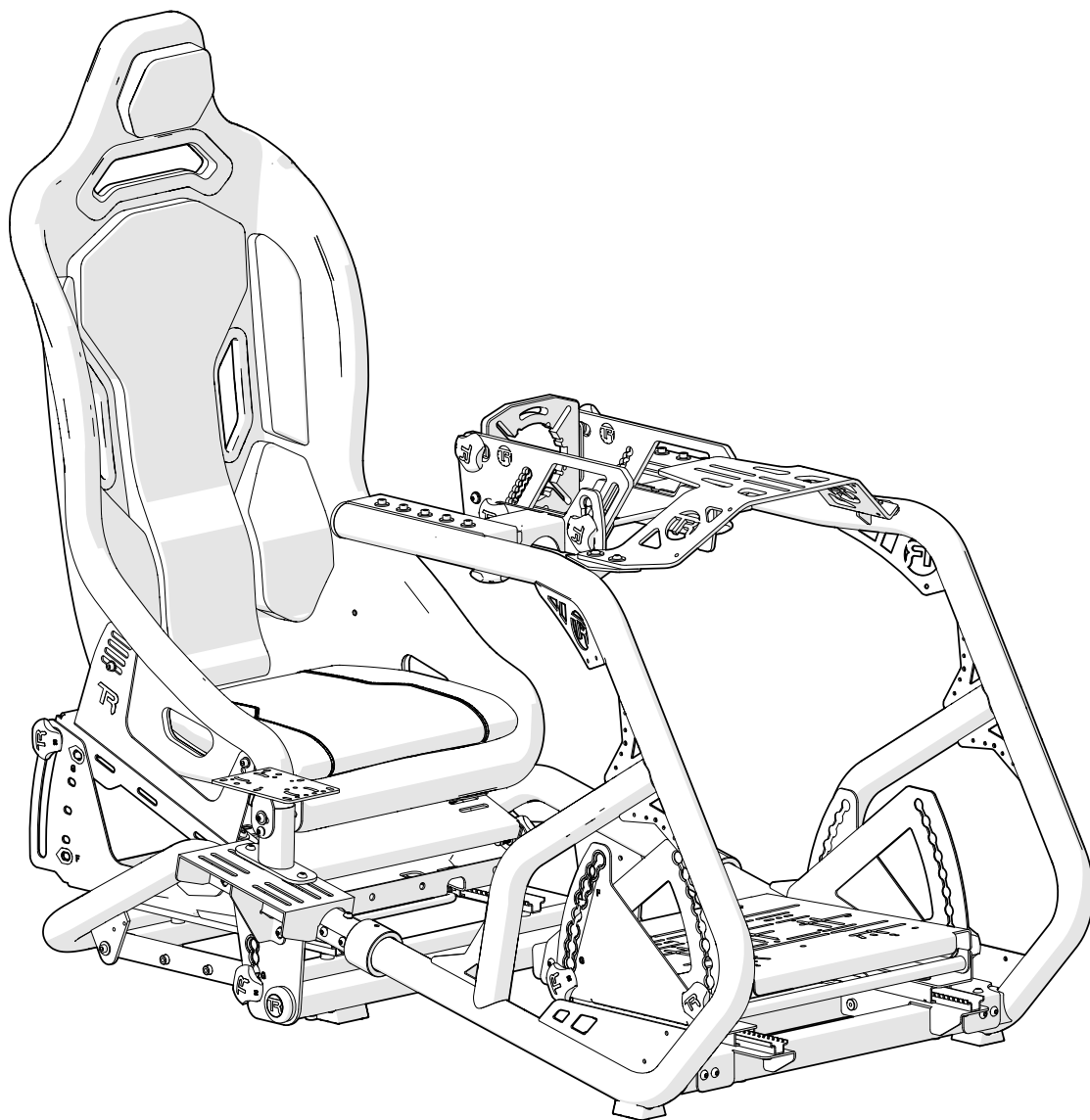

IMPORTANT: As there are different versions of each rig depending on your region, please ensure that you are using the correct instruction set. The part number below should match the part number labeled on your box

TRX-BLK & TRX-ALP



TRAK RACER

Published 2023-10-10

TABLE OF CONTENTS

3 Symbol Legend

4 Part list

7 Assembly Notes

8 TRX Assembly Instructions

16 Wheel Mounting Options

17 Wheel Mount OPTION 1: Universal Mount

24 Wheel Mount OPTION 2: Direct Drive Mount

31 Wheel Mount OPTION 3: Fanatec DD1 / DD2

33 Wheel Mount OPTION 2: Fanatec CSL DD

39 OPTIONAL: TRX-SEAT

42 OPTIONAL: TRX Shifter Mount

44 OPTIONAL: TRX Monitor Stand

50 OPTIONAL: Vesa Mount Extension Arms

52 OPTIONAL: Locking Wheels



IMPORTANT: As there are different versions of each rig depending on your region, please ensure that you are using the correct instruction set. The part number below should match the part number labeled on your box



IMPORTANT: Due to the nature of cut aluminium profile, some metal shavings may still be present after our extensive QA cleaning process. We recommend that boxes and packaging is opened on a hard floor.



NOTE: Some screws and washers are pre-installed and will need to be loosened and reattached according to the instructions.



Two people needed



Tighten hardware



Leave hardware loose for adjustment

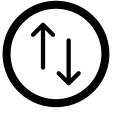

Make Adjustment



Break tab off Corner bracket CB1



Safety glasses needed



Attention / Priority



Reserve for following step



Mirrored Components (Same on both sides)

TRX PARTS LIST

NOTE: Some screws and washers come pre-installed. These will be part of the parts list and will need to be removed and reattached according to the instructions.



BOX #: TRX-BLK-PART1

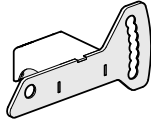

TRX-WLB **x1**
Wheel Tilt (Left)

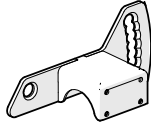

TRX-WRB **x1**
Wheel Tilt (Right)

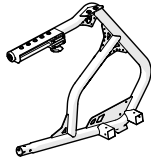

TRX-LB **x1**
Frame Front (Left)

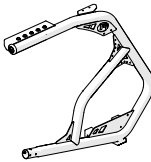

TRX-RB **x1**
Frame Front (Right)



TRX-TVSP **x1**
Monitor Stand Strut



TRX-SWP **x1**
Wheel Mount Part 2

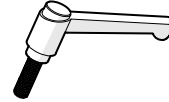

SL-M8-16 **x2**

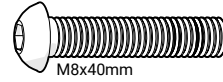

SB-M8-40 **x2**

M8x40mm

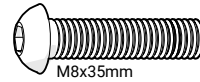

SB-M8-35 **x2**

M8x35mm

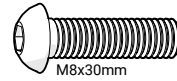

SB-M8-30 **x2**

M8x30mm

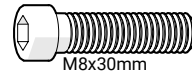

SH-M8-30 **x4**

M8x30mm



SB-M8-16 **x4**

M8x16mm

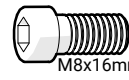

SH-M8-16 **x4**

M8x16mm



SB-M6-10 **x8**

M6x10mm



SF-M6-10 **x2**

M6x10mm



WF-M8 **x10**



WL-M8 **x10**



NC-M6 **x6**



NF-M8 **x4**



RC-M5 **x2**

INCLUDED TOOLS

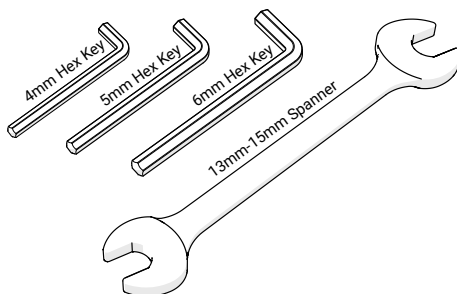

* NOTE: Extra hardware may be included as spare parts

TRX PARTS LIST

NOTE: Some screws and washers come pre-installed and will need to be removed and reattached according to the instructions.



BOX #: TRX-BLK-PART2

BOX #: TRX-BLK-PART3

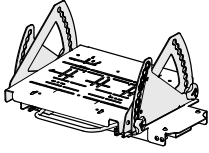

TRX-TB **x1**
Pedal Assembly

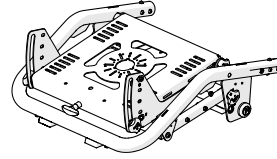

TRX-BA **x1**
Frame Rear

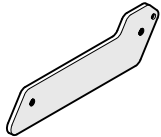

TRX-WLAP **x1**
Wheel Mount Part 2 (Right)

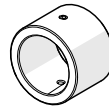

TRX-LH **x2**
Frame Collar

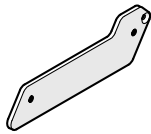

TRX-WRAP **x1**
Wheel Mount Part 2 (Left)



TRX-KNOB12 **2**
12mm Knob Screw

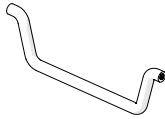

TRX-SWRL **x1**
Frame Front (Right)



TRX-KNOB14 **x4**
14mm Knob Screw

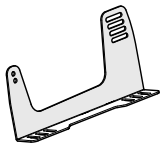

TRX-SPL **x1**
Seat Bracket (Left)



TRX-KNOB19 **x2**
19mm Knob Screw

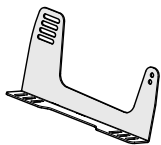

TRX-SPR **x1**
Seat Bracket (Right)



TRX-KNOB24 **x2**
24mm Knob Screw

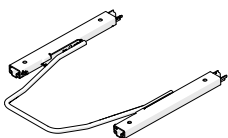

TRX-SLIDER **x2**
Seat / Pedal Slider



TRX-BUSH5 **x4**
Bushing, 5mm



TRX-BUSH10 **x4**
Bushing, 10mm



TRX-BUSH15 **x4**
Bushing, 15mm

* NOTE: Extra hardware may be included as spare parts

NOTE

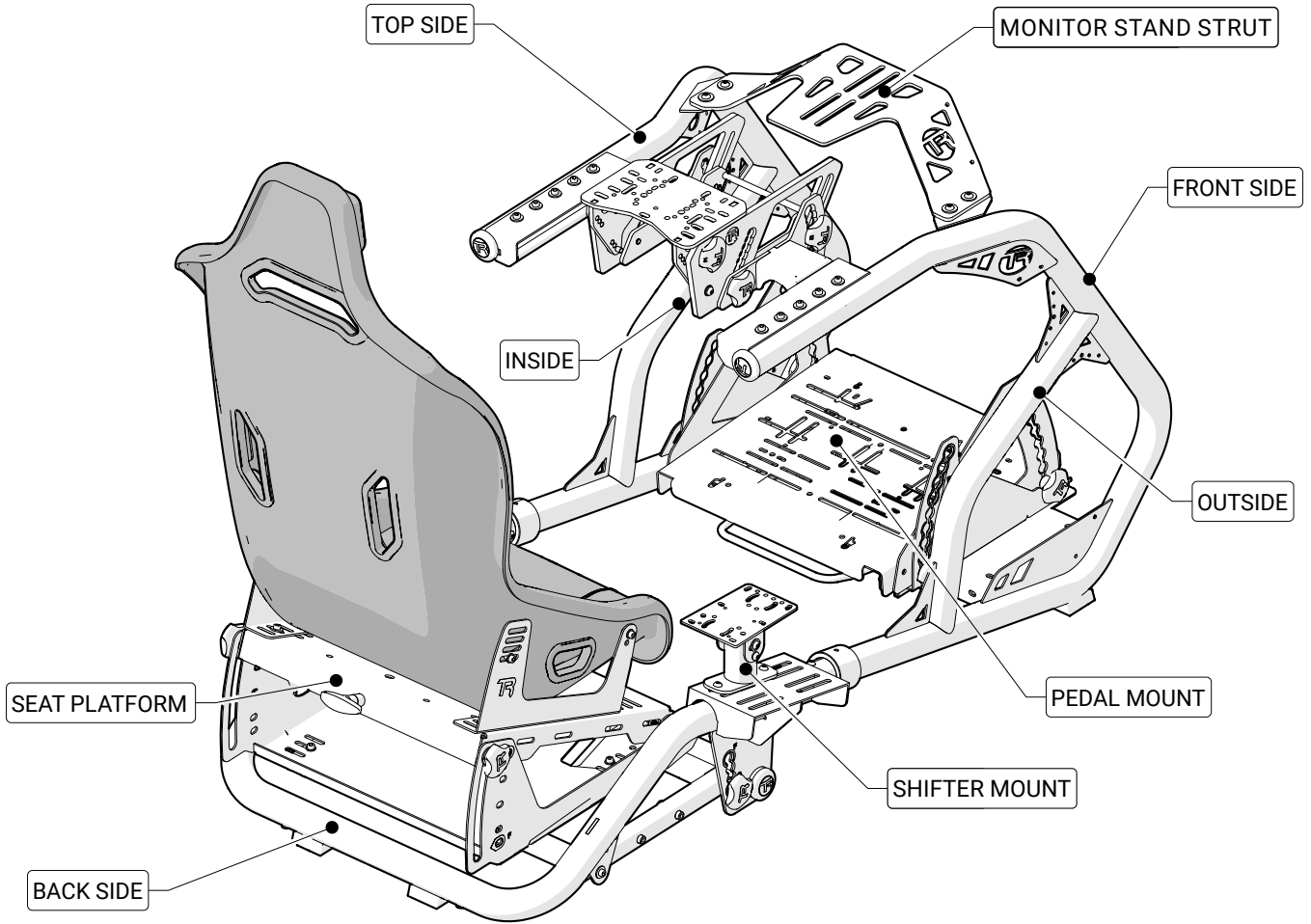

INSTALLATION ORDER FOR SCREWS & WASHERS

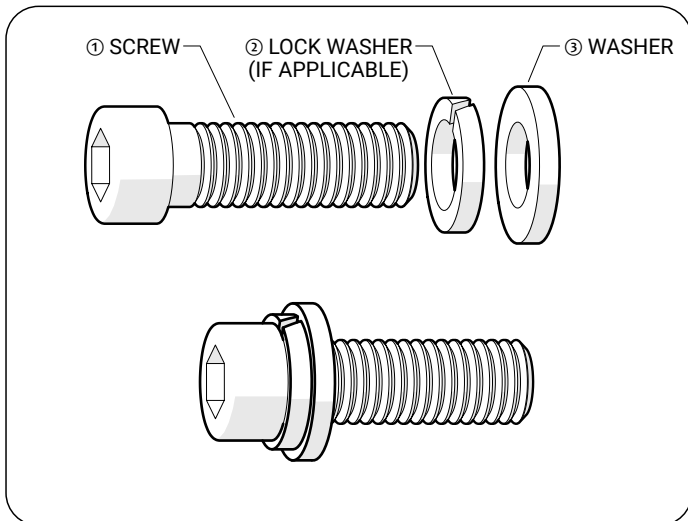

HOW TO MEASURE SCREWS

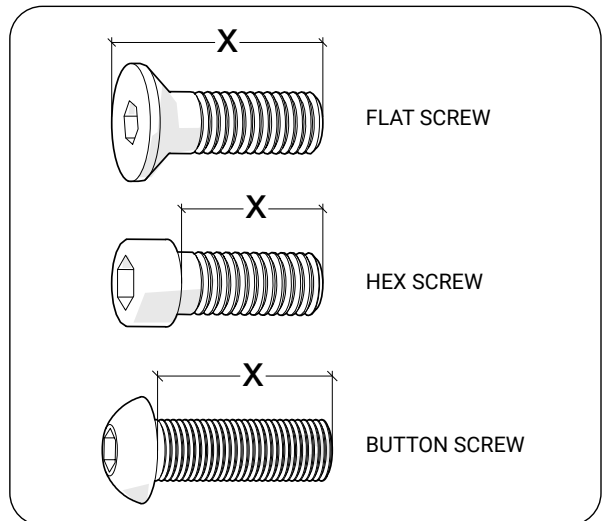

1

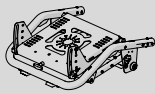

TRX-BA x1

NOTE: Some screws and washers come pre-installed and will need to be loosened and reattached according to the instructions.



a

Slightly loosen the two knob screws located at the back of the seat platform

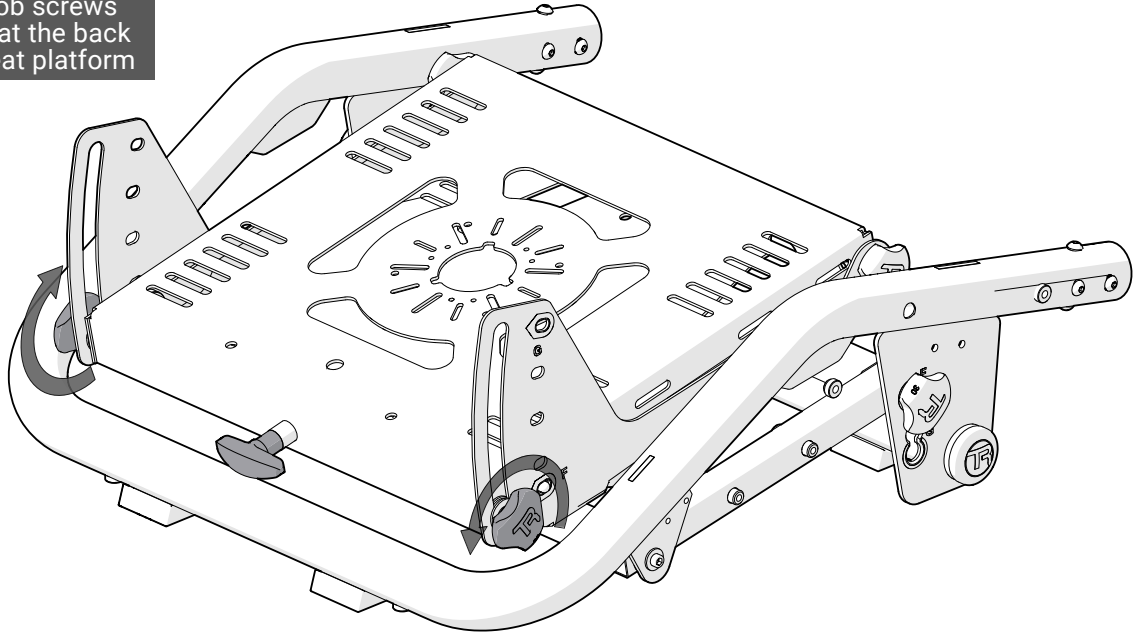

b

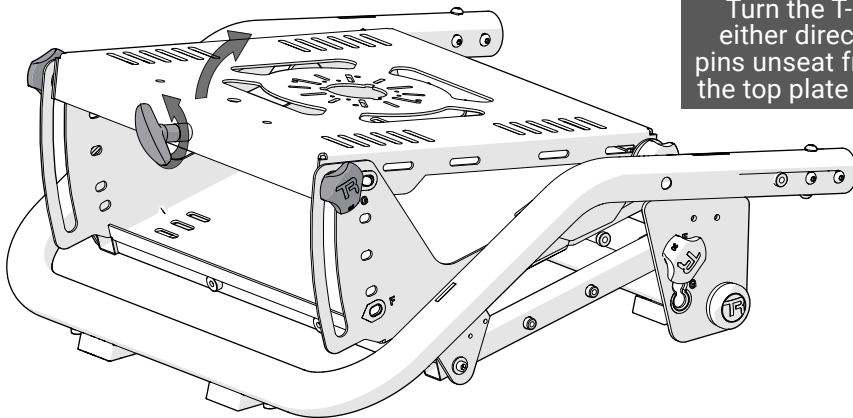

Turn the T-handle at the rear in either direction until the locking pins unseat from their holes and lift the top plate to the top "G" position

c

Once the locking pins are re-seated into the top holes with a "click", tighten the knob screws to lock the platform

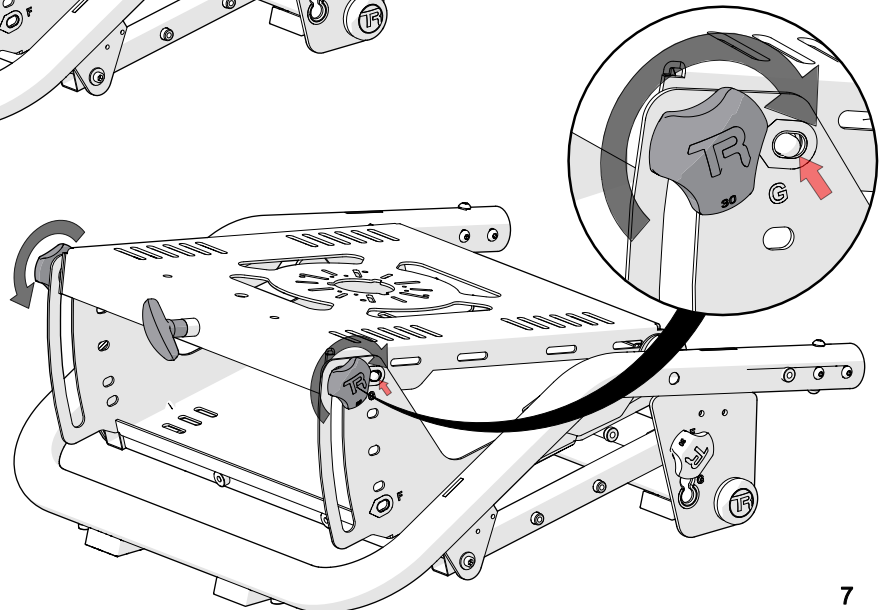

2

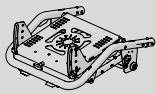

TRX-BA x1

Remove the seat platform assembly by removing the 4 screws and set everything aside

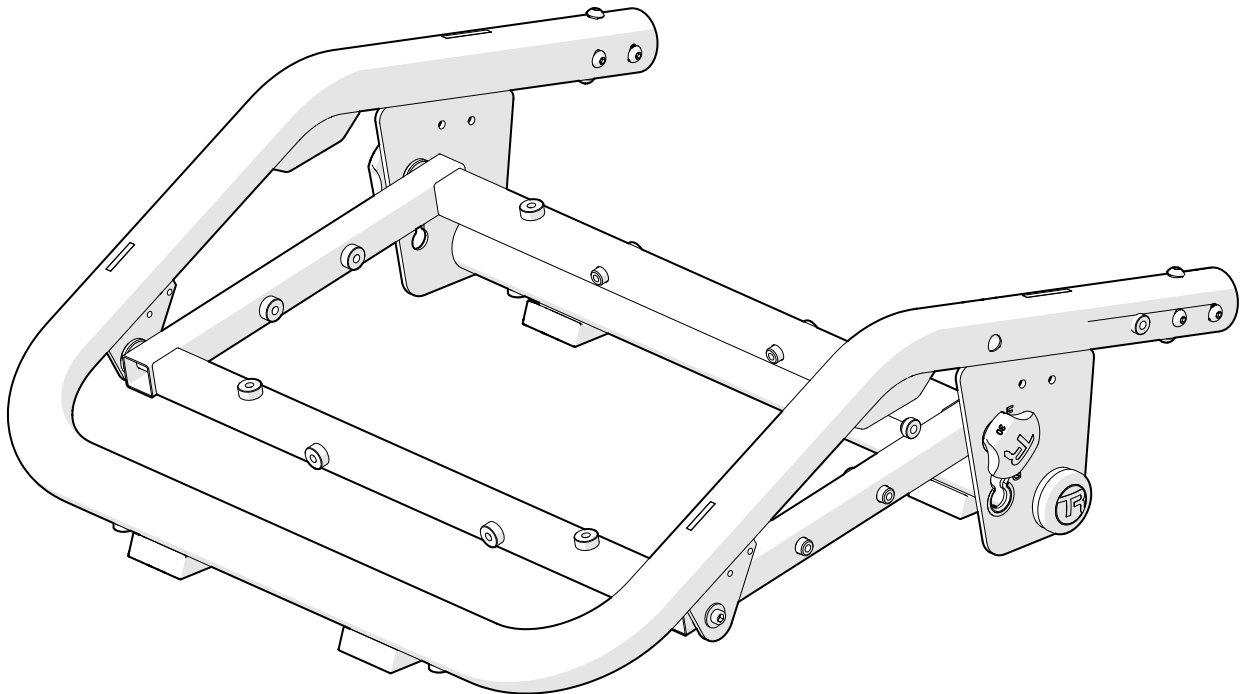
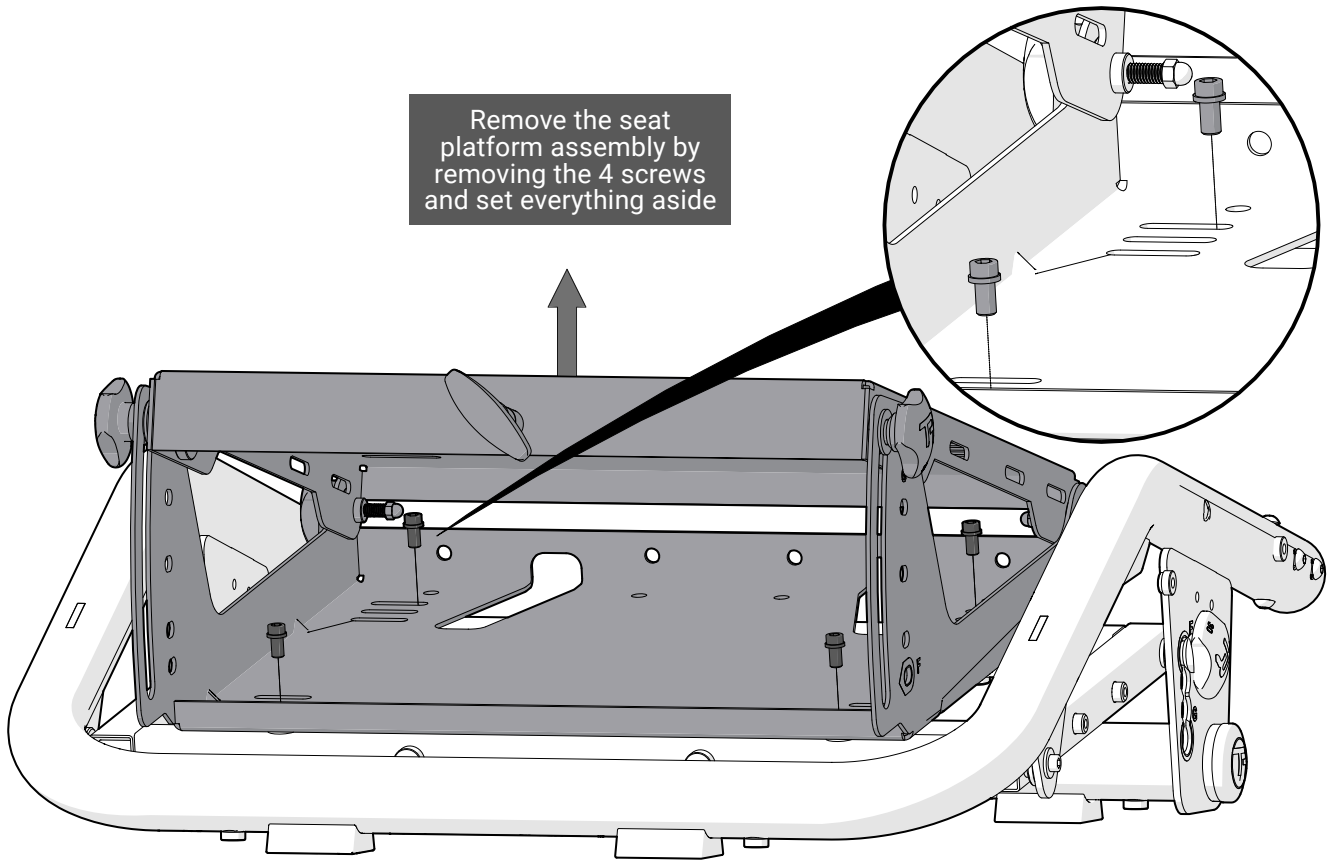

3

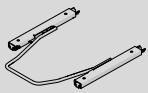

TRX-SLIDER x1



SH-M8-16 x4



WL-M8 x4

NOTE: Some screws and washers come pre-installed and will need to be removed and reattached according to the instructions.

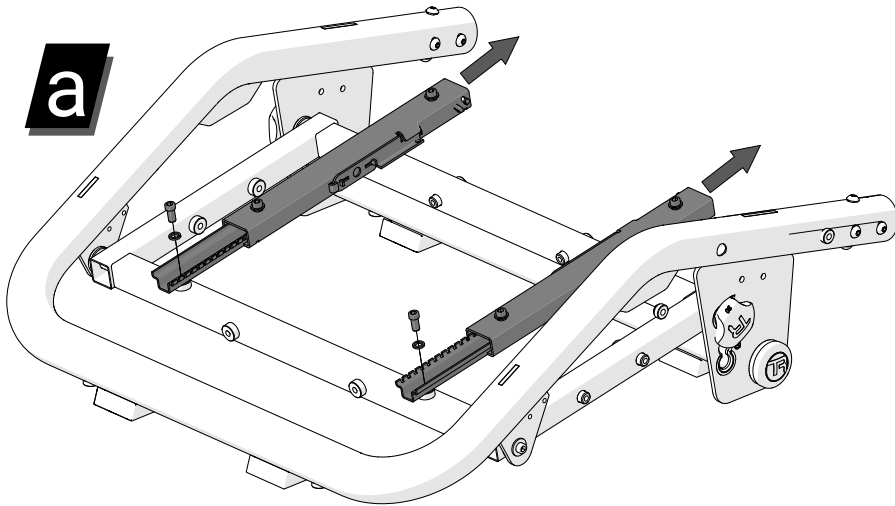

Fit tabs into holes of one side of the handlebar, then squeeze handlebar and repeat for opposite side

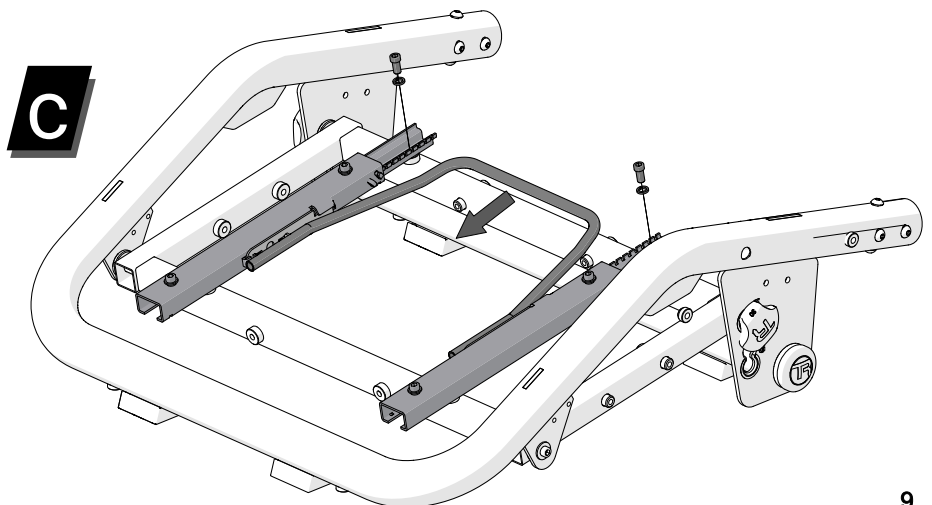
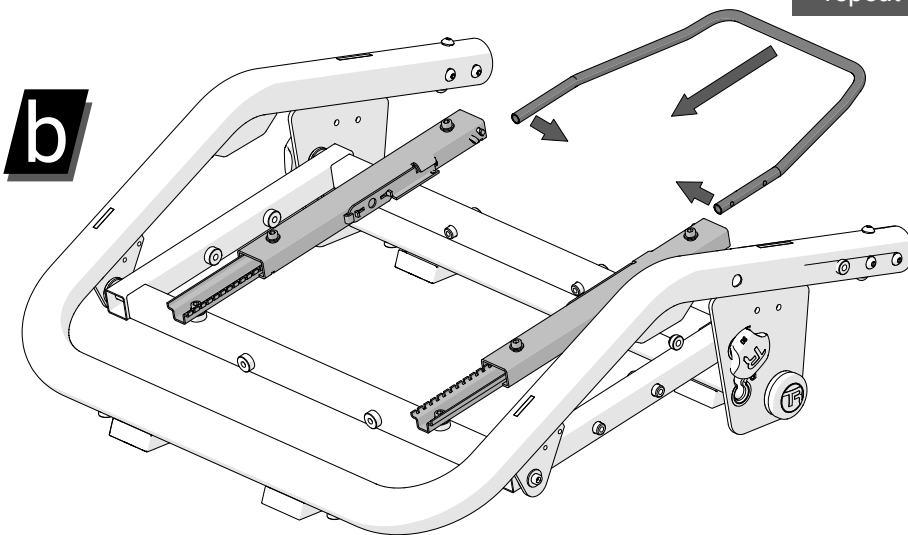

4

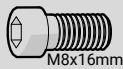

M8x16mm

SH-M8-16 x4



WF-M8 x4

NOTE: Some screws and washers come pre-installed and will need to be loosened and reattached according to the instructions.



Reattach the seat platform to the seat slider

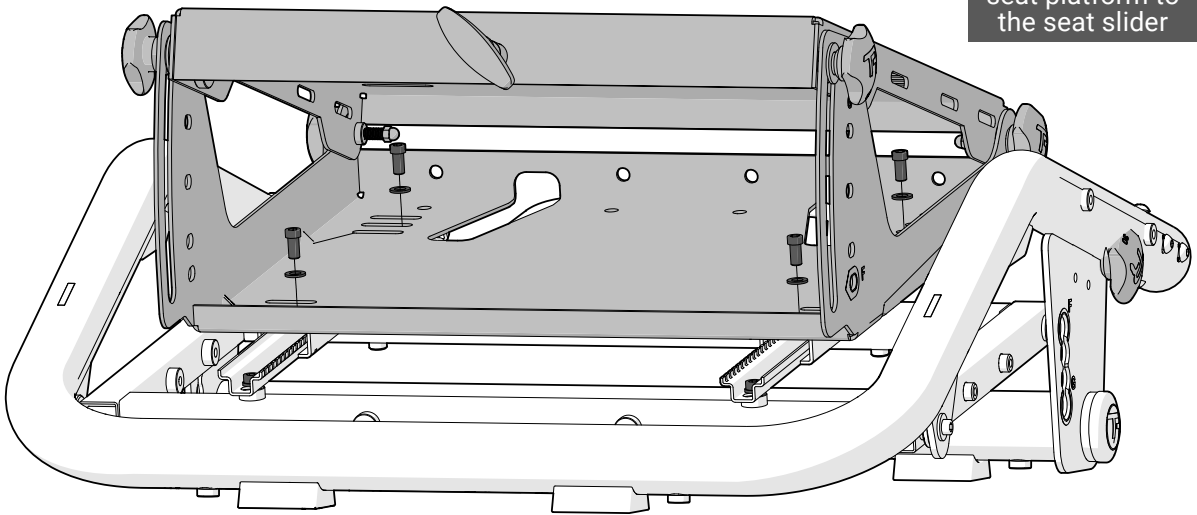

5

NOTE: If the locking seat platform locking mechanism are loose, tighten the eyelets on both sides by holding the centre turnbuckle and tighten accordingly.

DO NOT OVERTIGHTEN

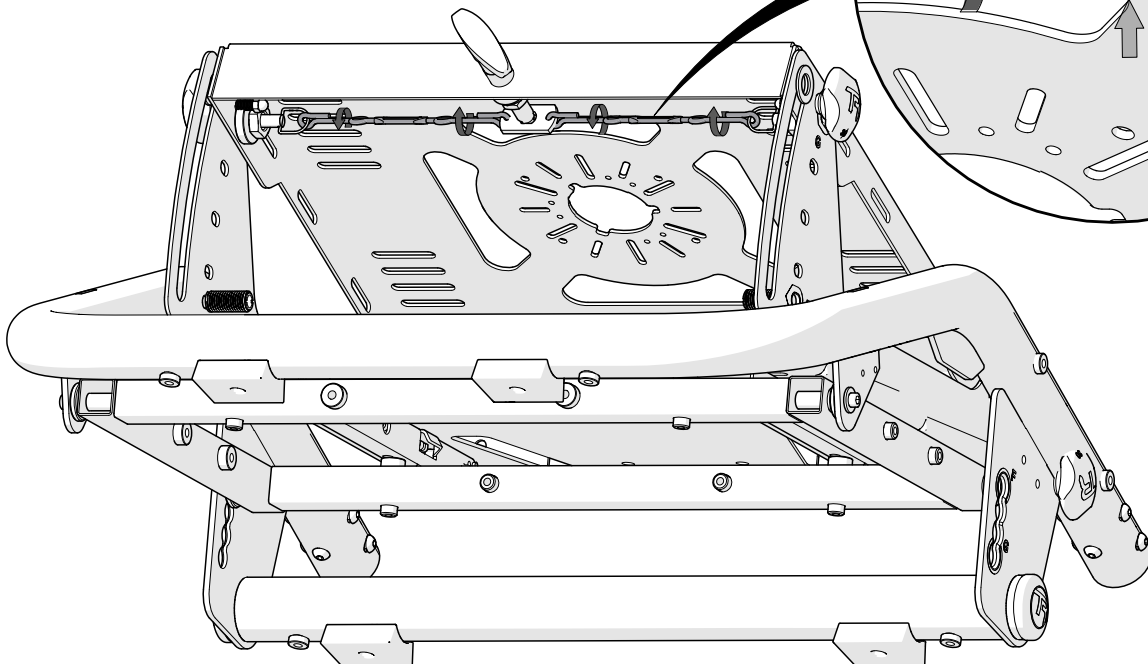
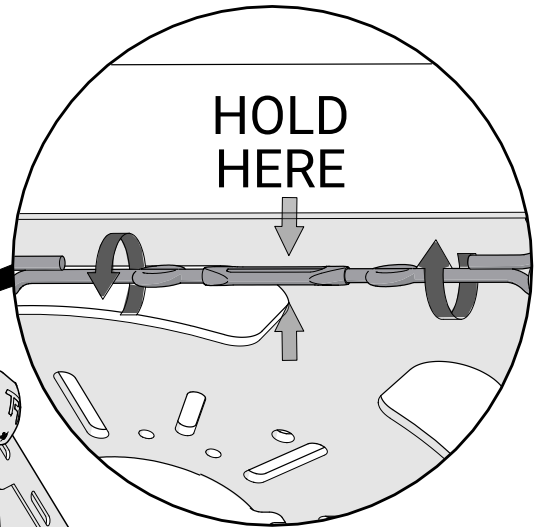

6



TRX-LH x1



TRX-RB x1

NOTE: Some screws and washers come pre-installed and will need to be loosened and reattached according to the instructions.



a

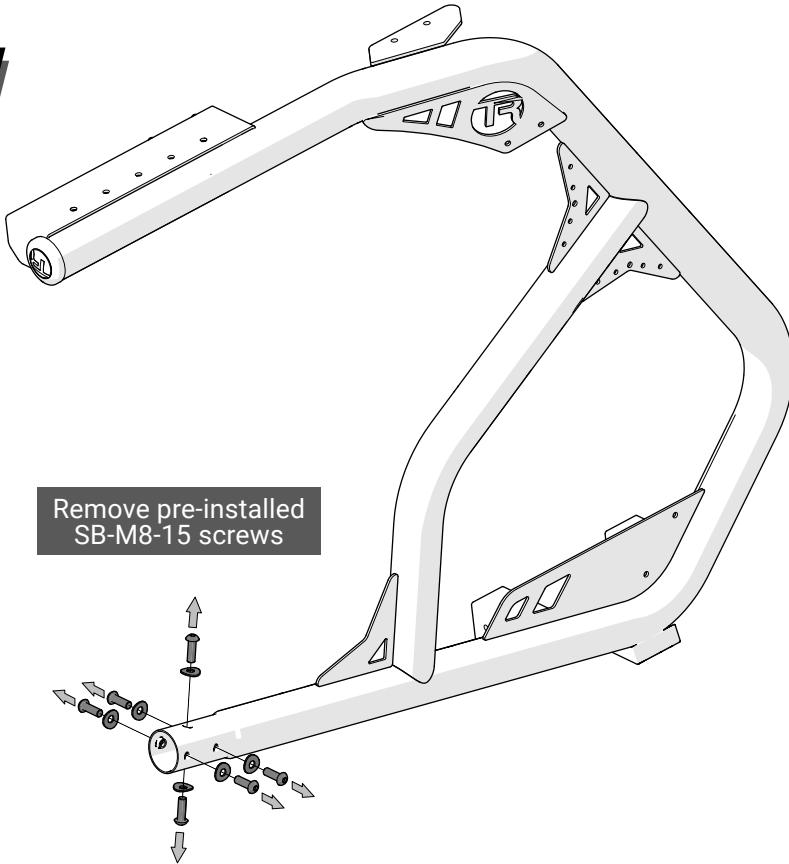

Remove pre-installed
SB-M8-15 screws

b



Slightly loosen the two set
screws pre-installed in TRX-LH
and slide over TRX-RB.
Keep screws loose until STEP 18

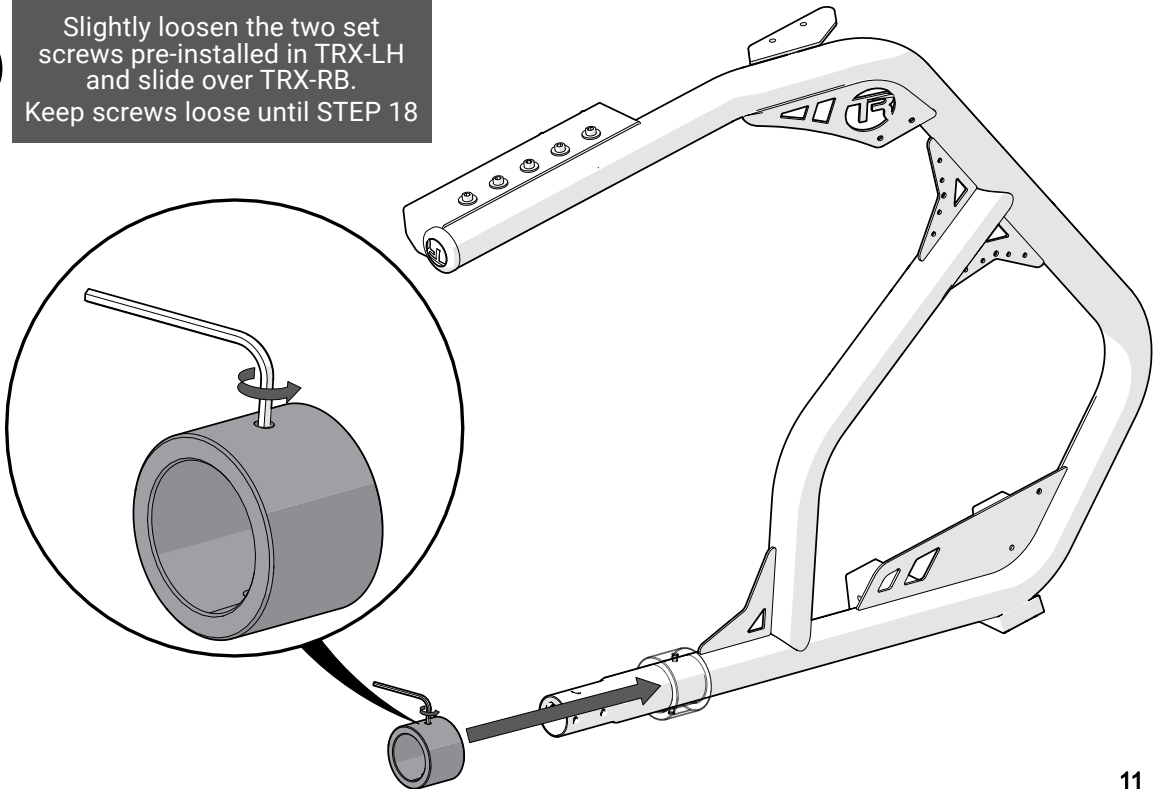

7

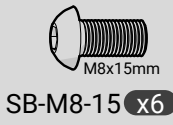

NOTE: Some screws and washers come pre-installed and will need to be loosened and reattached according to the instructions.



a

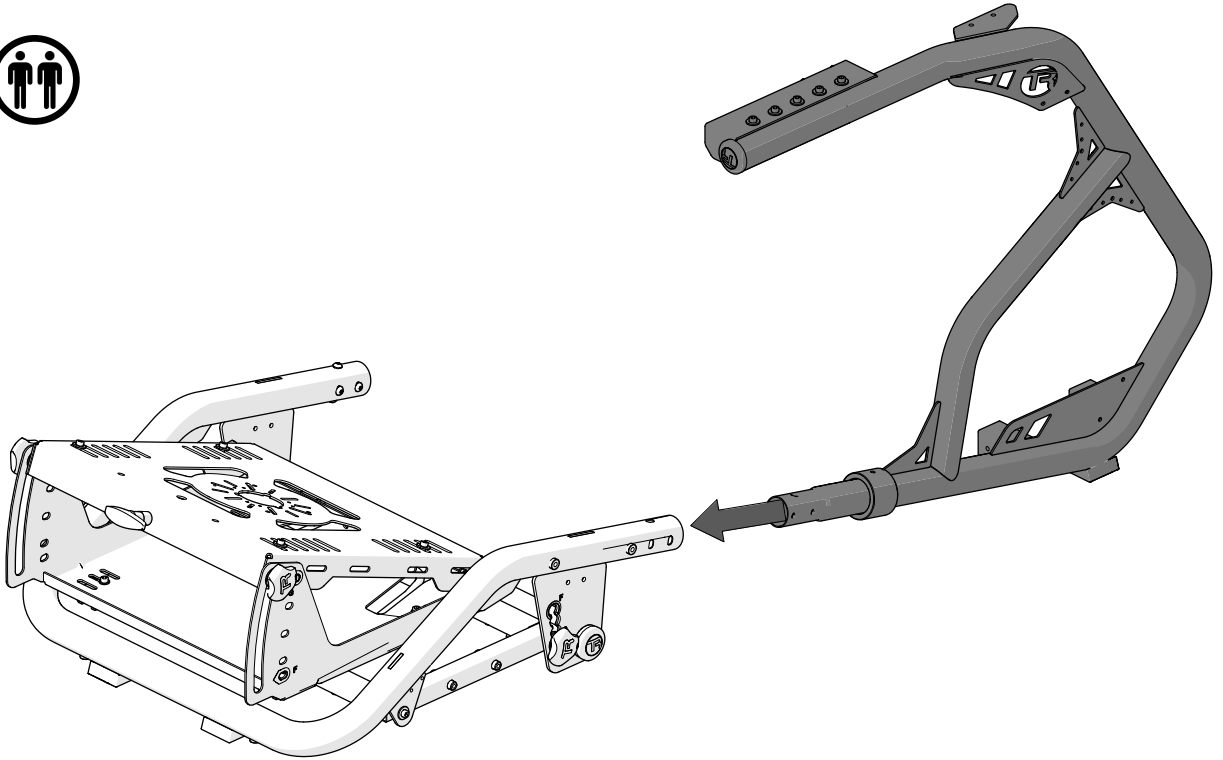

b



Reinstall and keep screws slightly loose until STEP 17

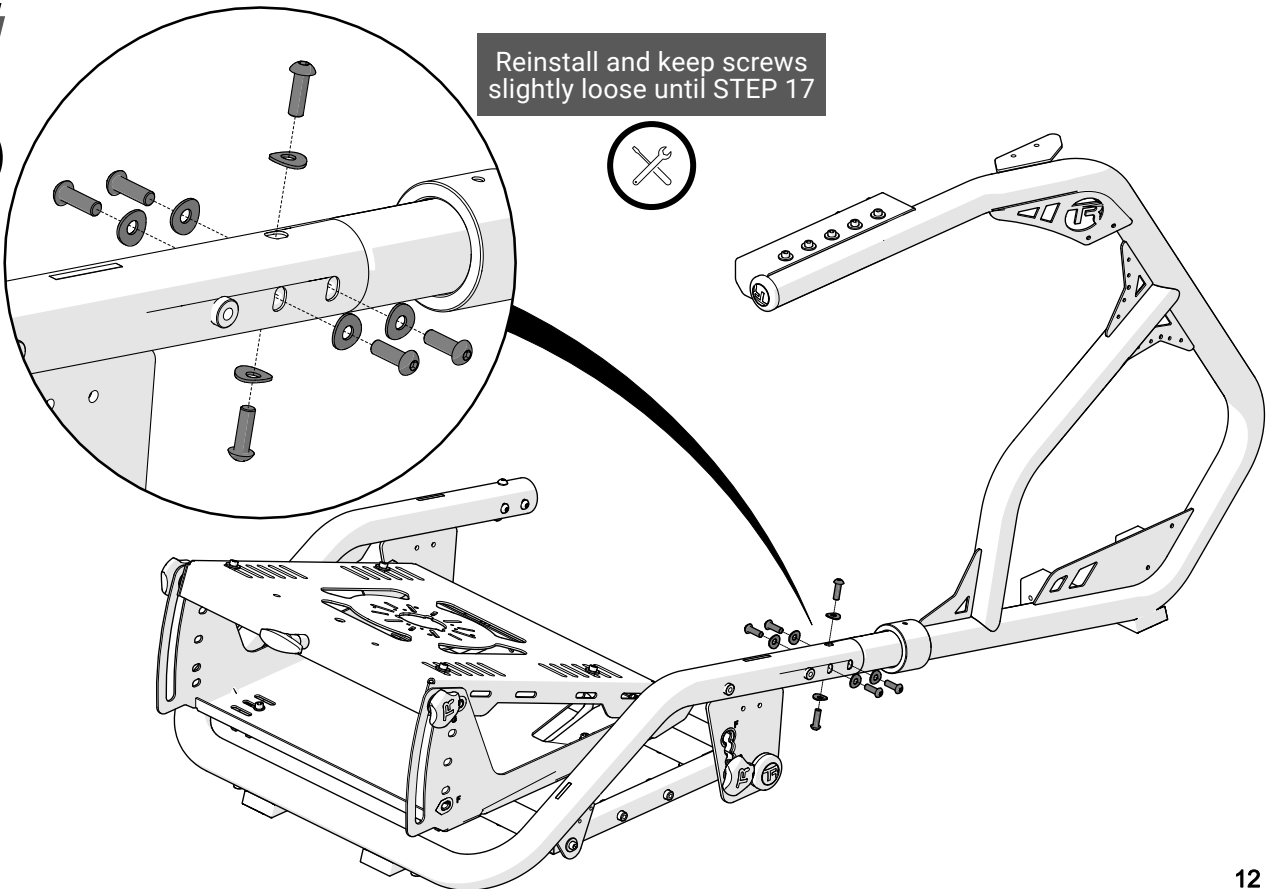

8



TRX-LH x1



TRX-LB x1

NOTE: Some screws and washers come pre-installed and will need to be loosened and reattached according to the instructions.



a

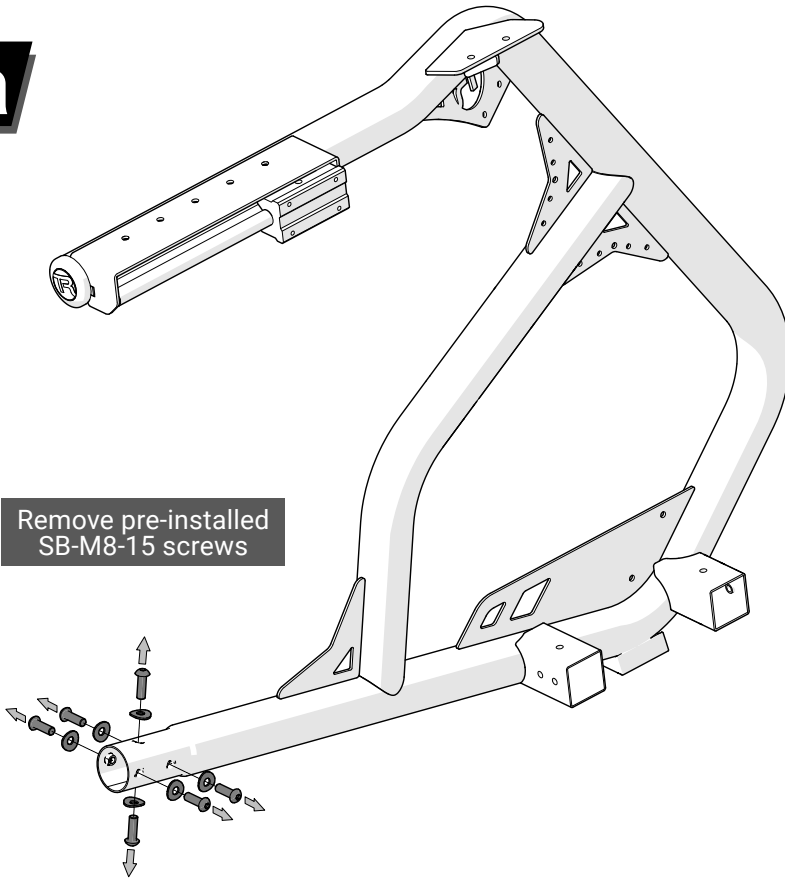

Remove pre-installed SB-M8-15 screws

b



Slightly loosen the two set screws pre-installed in TRX-LH and slide over TRX-RB. Keep screws loose until STEP 18

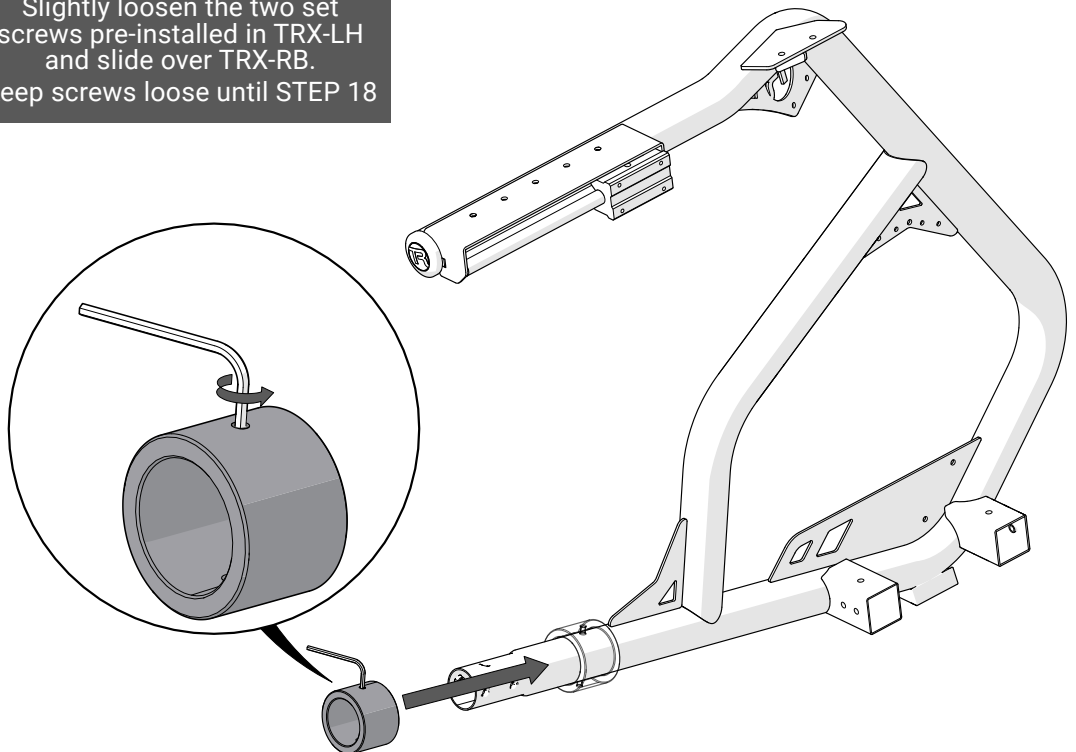

9



TRX-LB x1

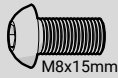

SB-M8-15 x6



WC-M8 x6

NOTE: Some screws and washers come pre-installed and will need to be loosened and reattached according to the instructions.



a

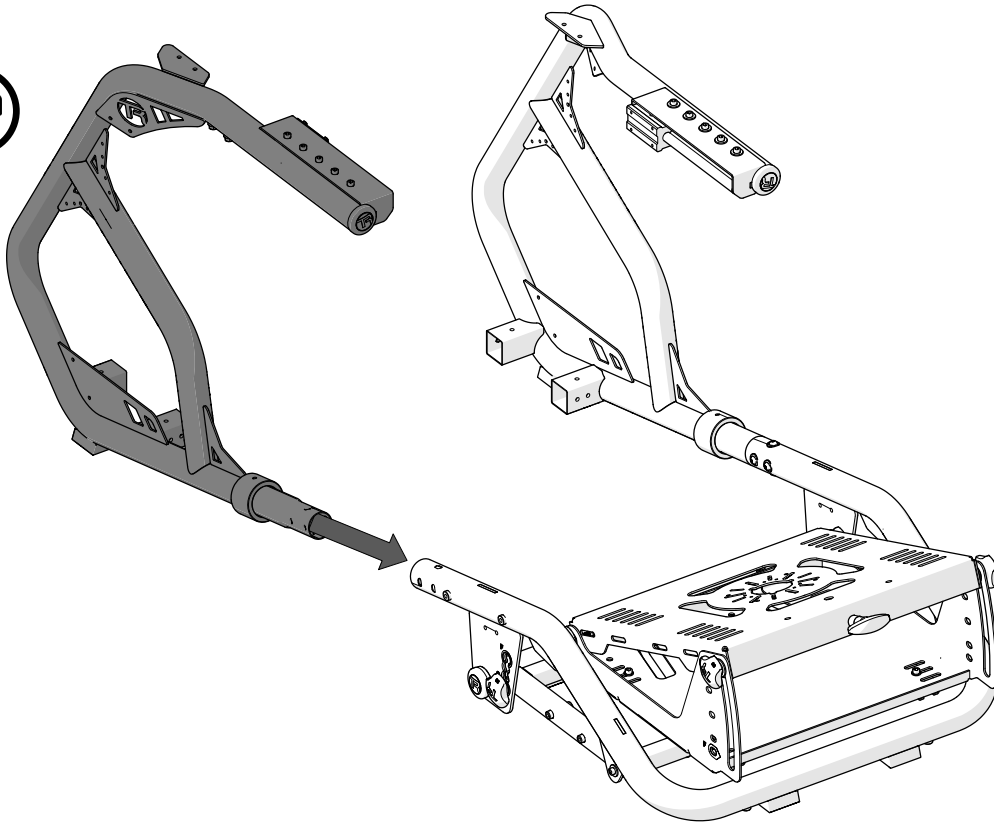

b



Reinstall and keep screws slightly loose until STEP 17

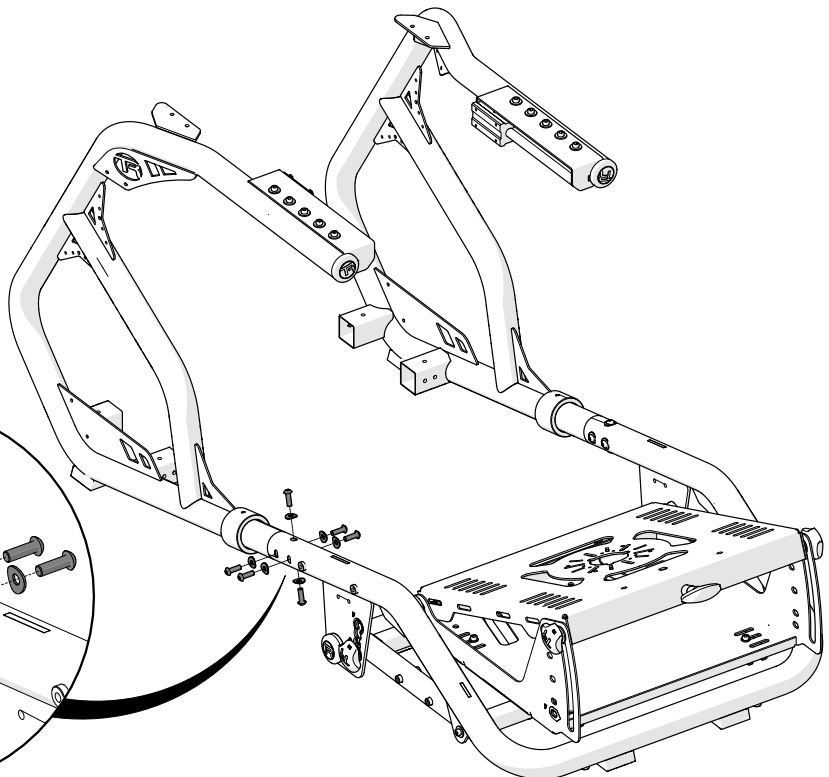
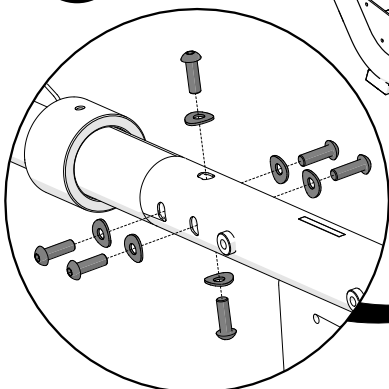

10

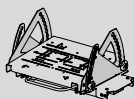

TRX-TB x1

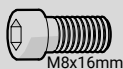

SH-M8-16 x12



WF-M8 x12

NOTE: Some screws and washers come pre-installed and will need to be loosened and reattached according to the instructions.



a

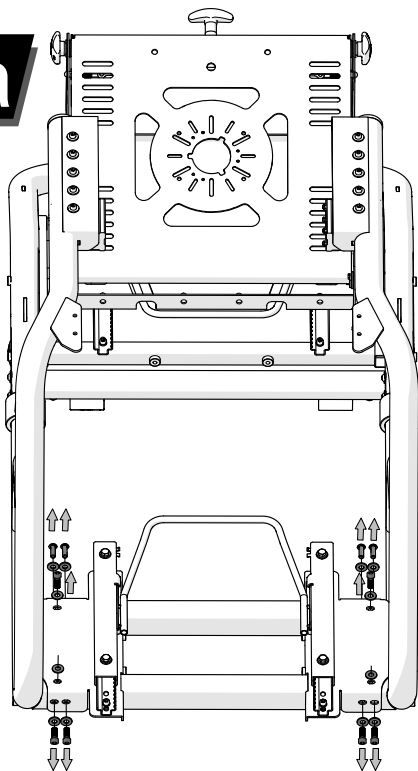

Remove pre-installed
SH-M8-16 screws (x12)
& WF-M8 (12)

b

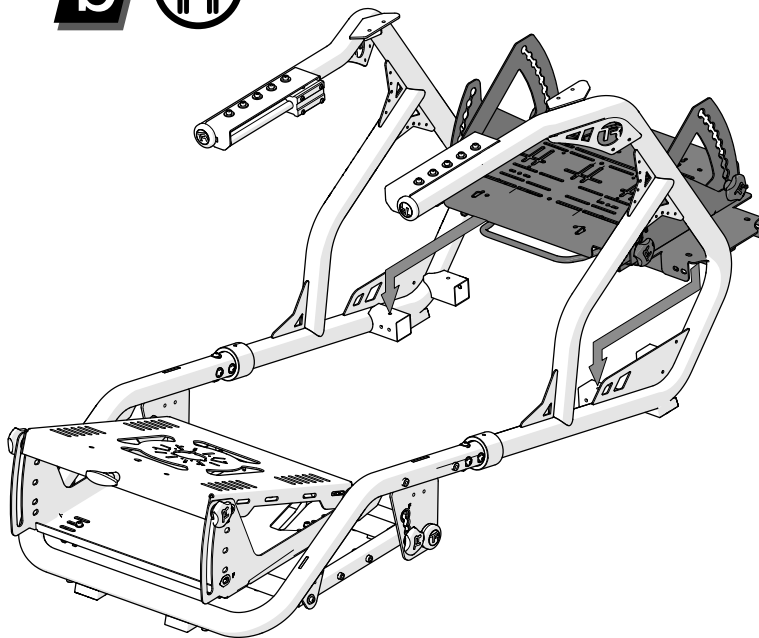

c

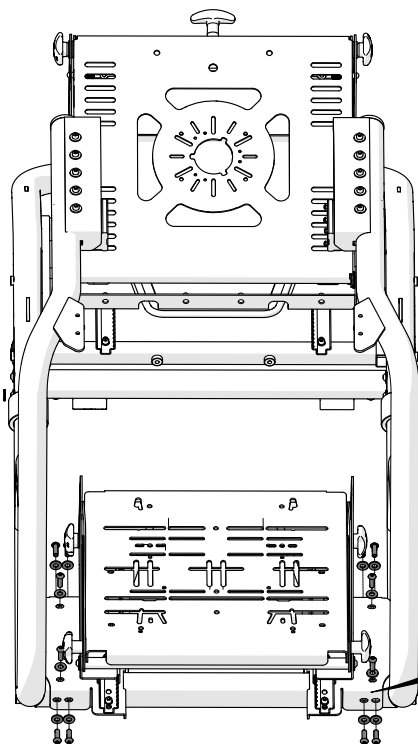

Re-install SH-M8-16
& WF-M8

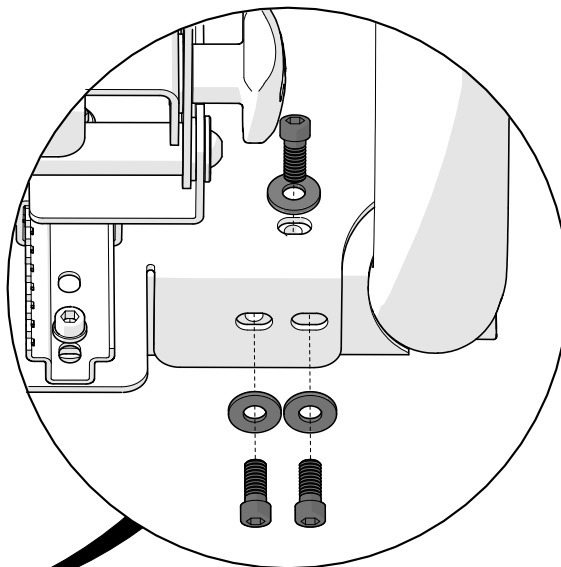

Keep screws slightly
loose until STEP 19



NOTE

Please skip to the pages corresponding to the wheelbase mounting method you have chosen for your TRX rig

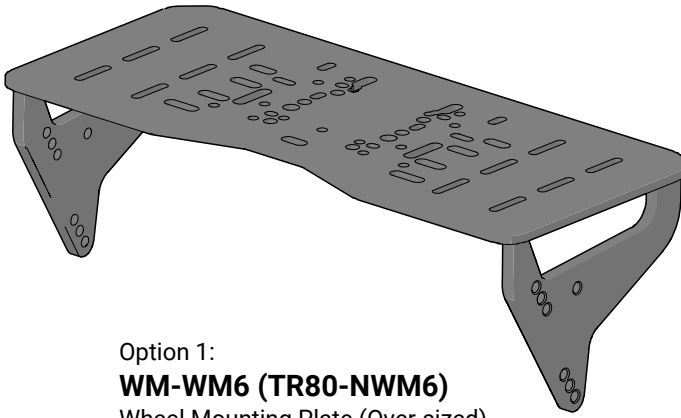

Option 1:
WM-WM6 (TR80-NWM6)
Wheel Mounting Plate (Over-sized)
Page 17

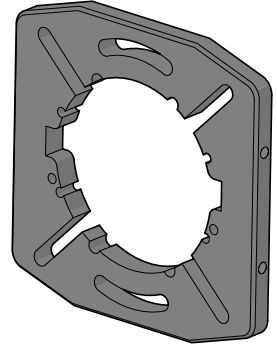

Option 2:
WM-DD (TR80-NWMDD)
Wheel Mounting, Direct Drive
Page 24

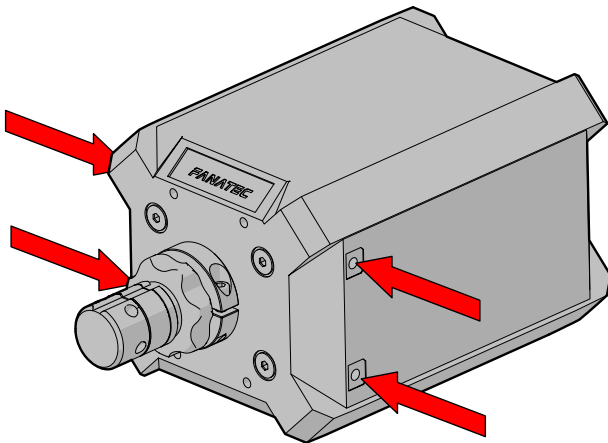

Option 3:
FANATEC PODIUM DD1 / DD2
Side Mount
Page 23

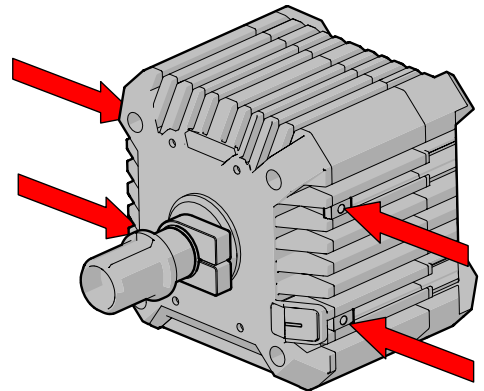

Option 4:
FANATEC CSL DD
Side Mount
Page 23

For all other wheel mounting methods, please contact customer support.

OPTION 1: Universal Wheel Mount

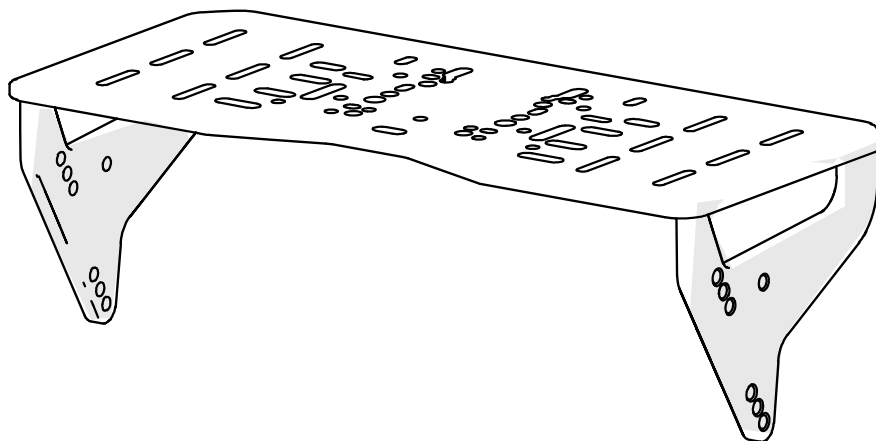

Part #	Image	Description	QTY	Check
WM-NWM6		Wheel Mount, Universal Oversize	1	
WM6-TILT-L		NWM6 Tilt (Left)	1	
WM6-TILT-R		NWM6 Tilt (Right)	1	
TRX-KNOB8		8mm Knob Screw	2	
TRX-KNOB12		12mm Knob Screw	2	
SB-M8-20		Screw (Button), M8 x 20mm	2	
WL-M8		Washer (Lock), M8	2	
SF-M6-16		Screw (Flat), M6 x 16mm	8	
RC-M5		Retainer Clip, M5	2	

* **NOTE:** Extra hardware may be included as spare parts

TR-80-NWM6



TRAK RACER

Published 2023-10-10

11



WM6-TILT-L x1



WM6-TILT-R x1



SF-M6-16 x8

NOTE: Some screws and washers come pre-installed. These will be part of the parts list and will need to be removed and reattached according to the instructions.



NOTE: Due to the slider blocks being made of aluminum, be cautious to not cross-thread when tightening screws

a

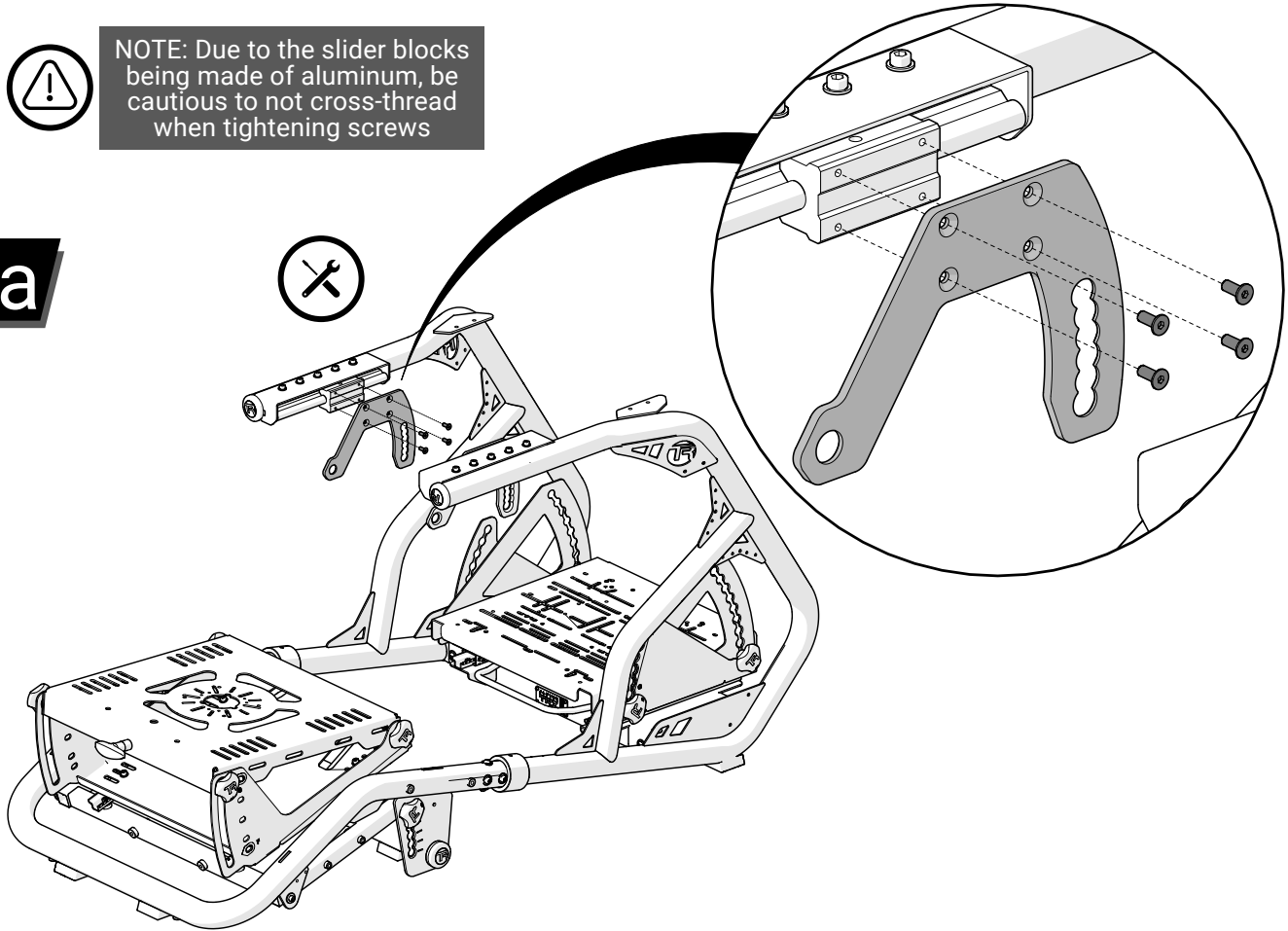

b

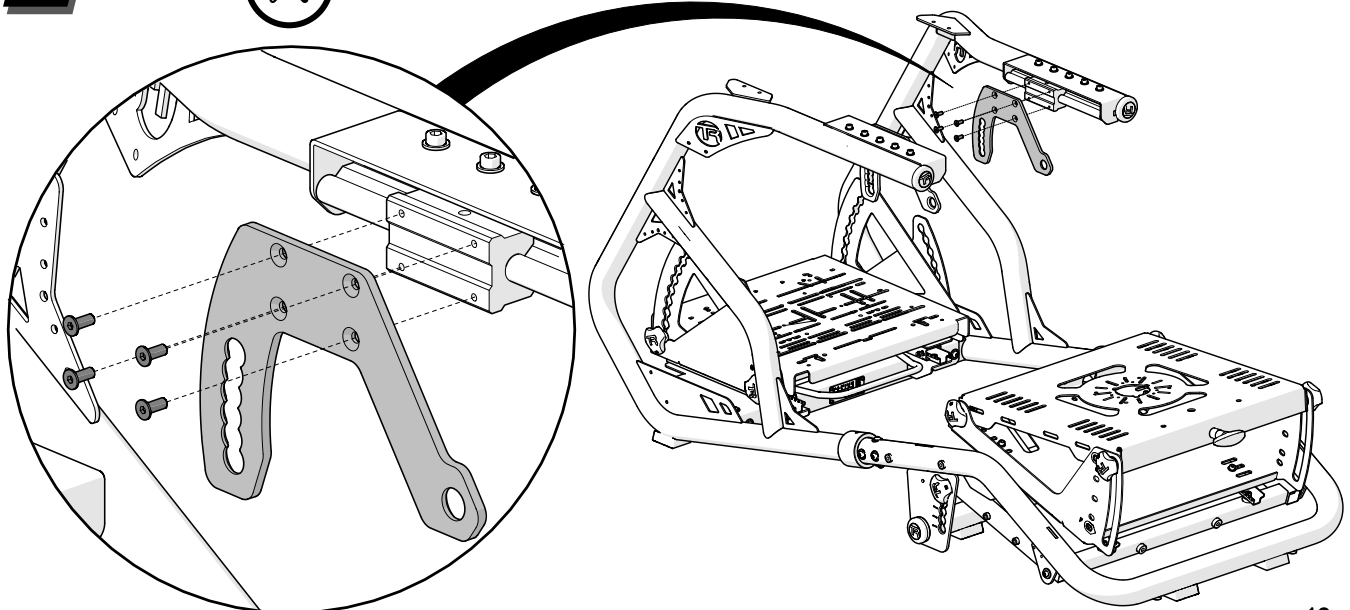

12



TRX-SWP x1

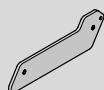

TRX-WLAP x1



TRX-KNOB12 x2



RC-M5 x2

a

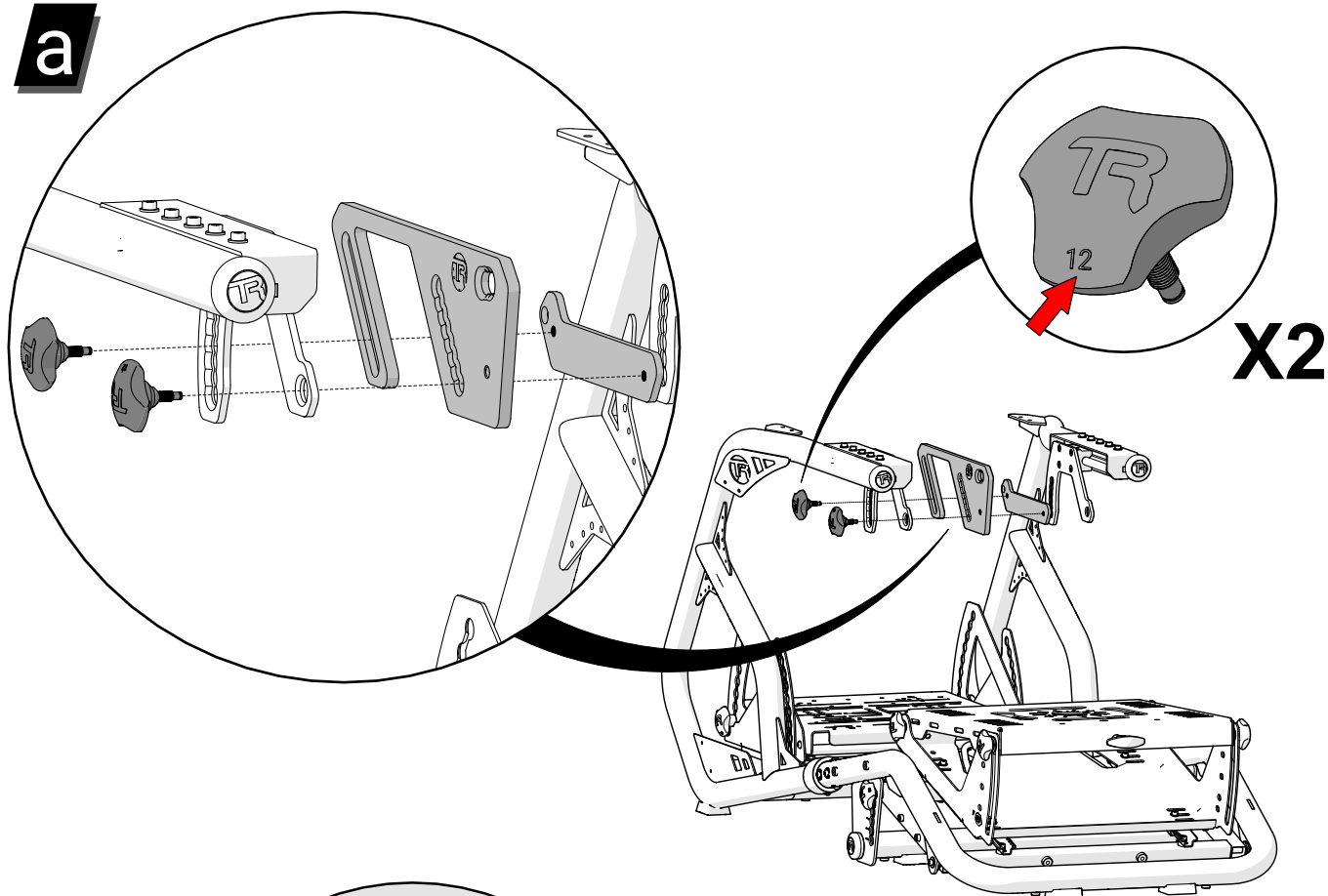

X2

b

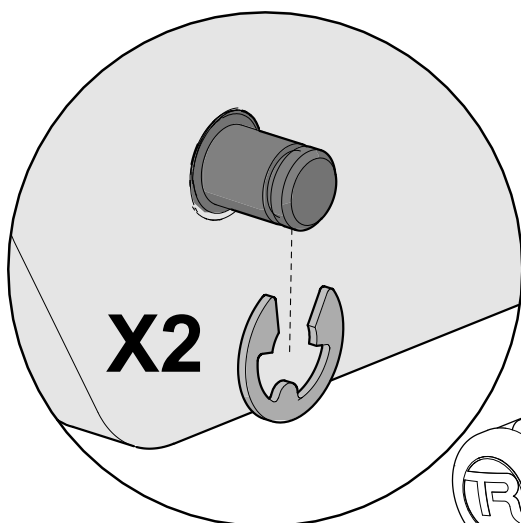

X2

Press RC-M5 into groove of TRX-KNOB12 after threading in.

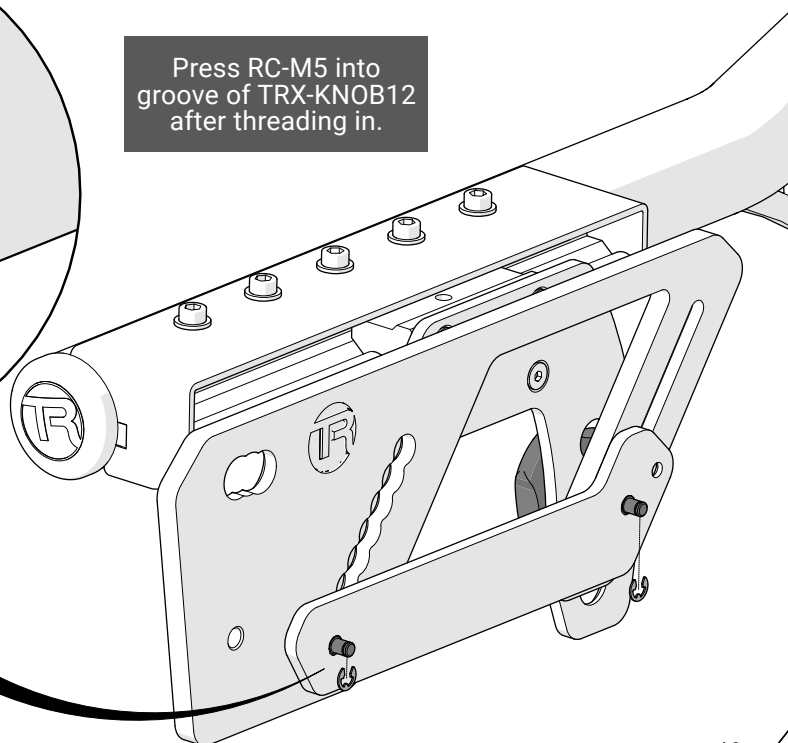

13



TRX-SWP x1



TRX-WRAP x1



TRX-KNOB12 x2



RC-M5 x2

NOTE: TR-SWRL is an assembly rod used to maintain alignment of your wheel mount. It will not add rigidity. This part can be removed if it impedes with your wheel base.



a

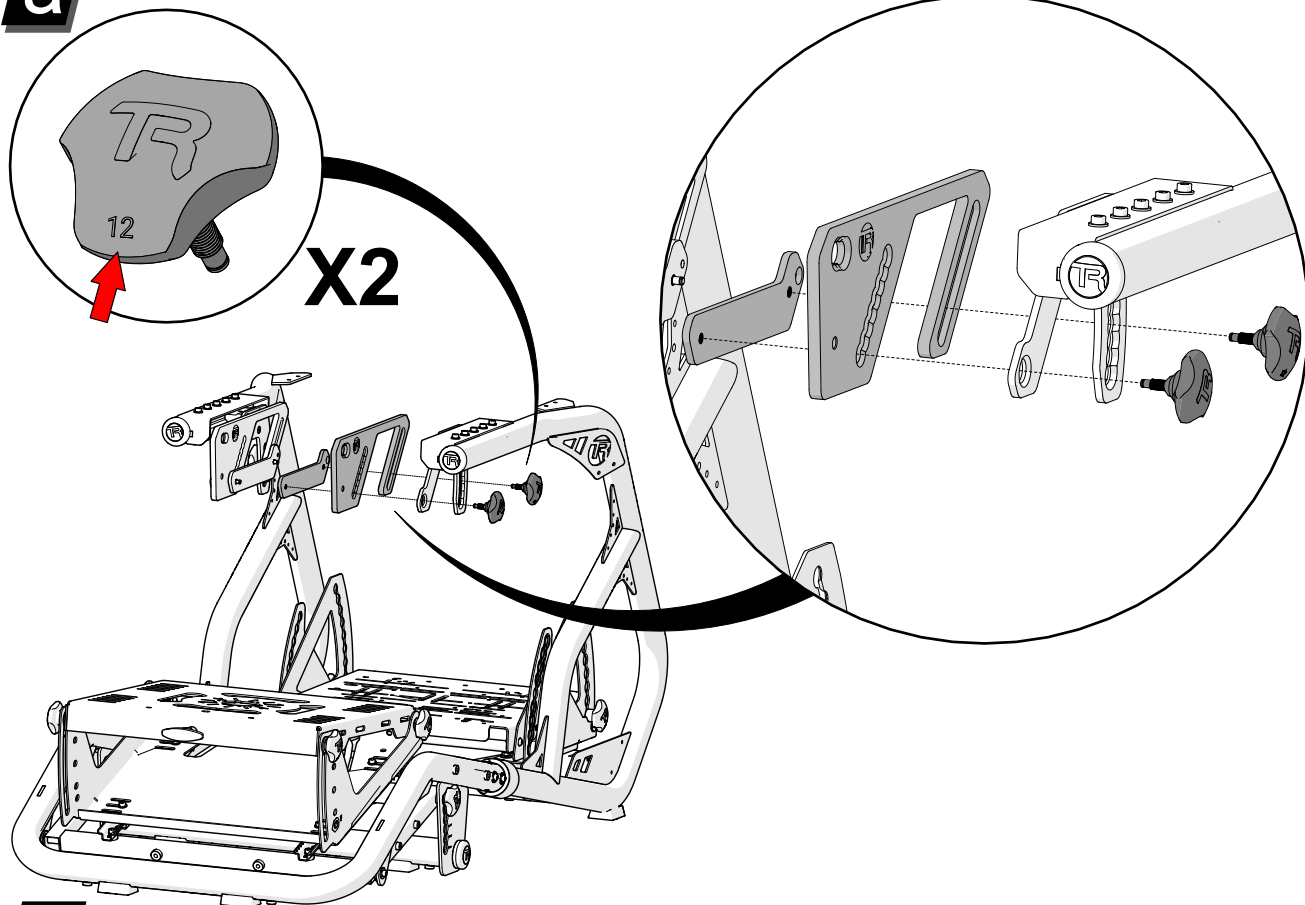

b

Press RC-M5 into groove of TRX-KNOB12 after threading in.

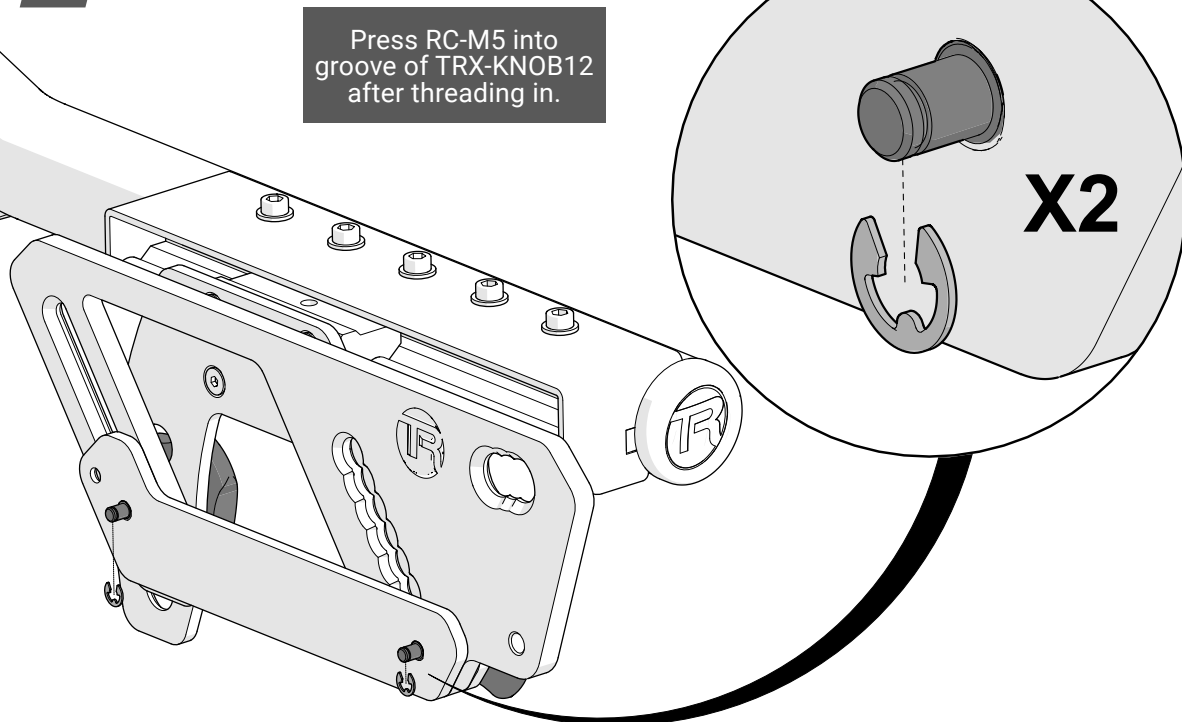

14

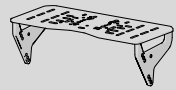

WM-WM6 x1



TRX-KNOB8 x2

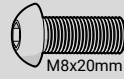

SB-M8-20 x2



WL-M6 x2

ORIENTATION 1

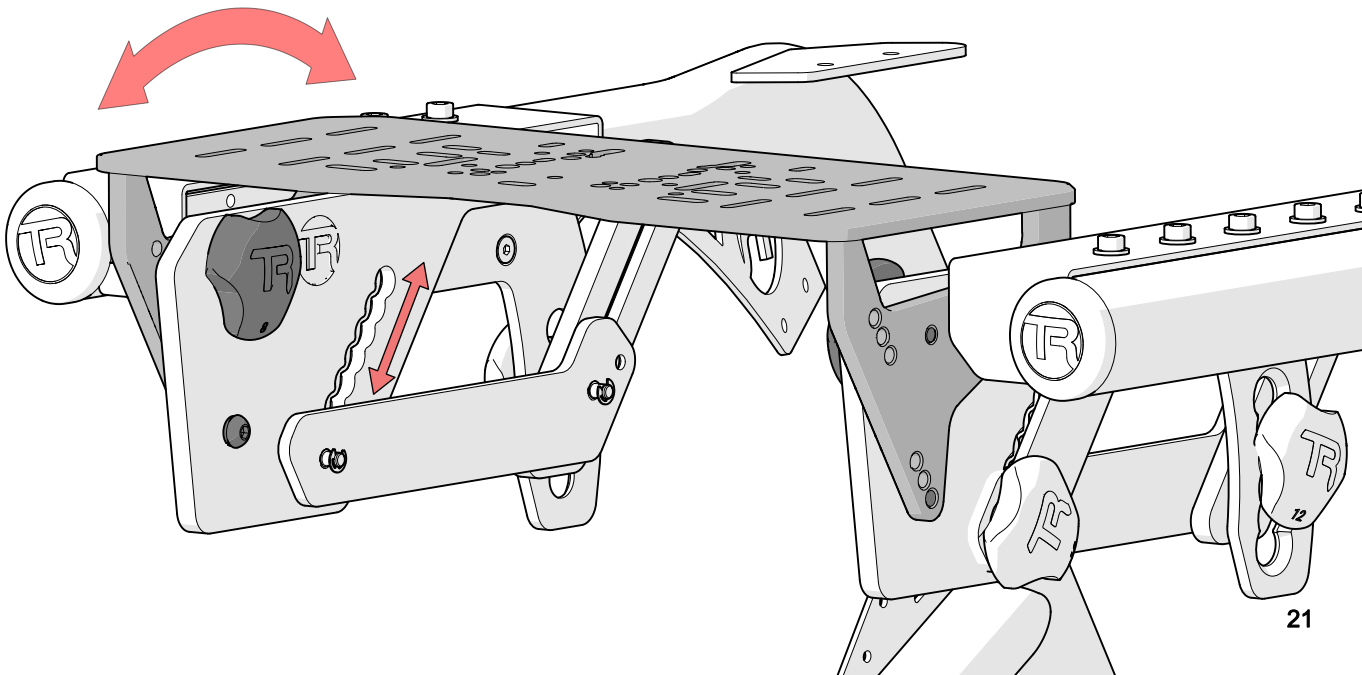
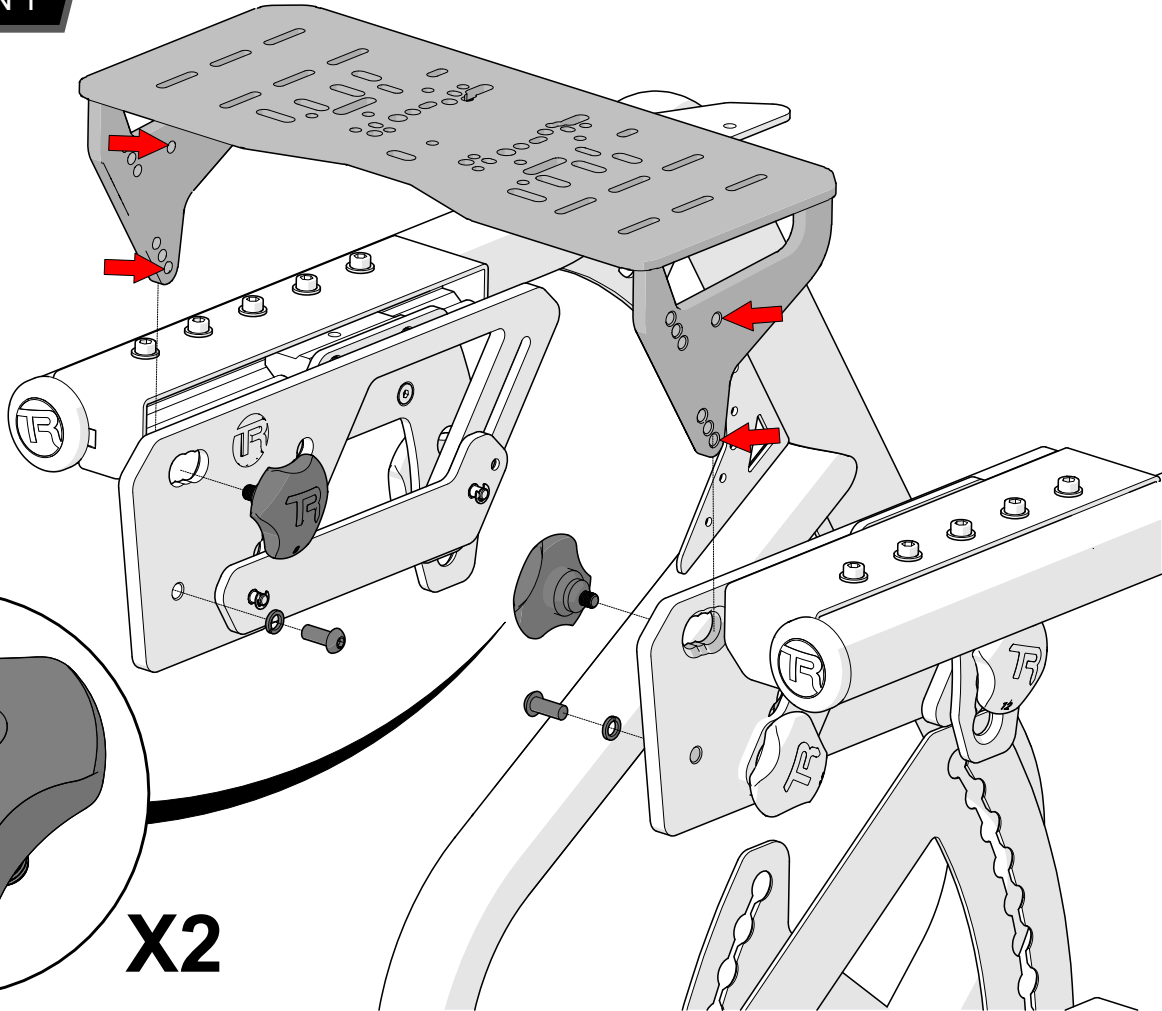

14



WM-WM6 x1



TRX-KNOB8 x2

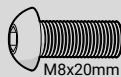

SB-M8-20 x2



WL-M6 x2

ORIENTATION 2

a

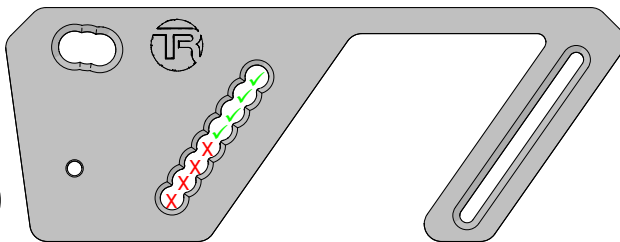

NOTE: In order to use WM-WM6 (TR80-NWM6) upside down, loosen the hand screws and slide both side plates down to one of the top 4 holes shown with the green checks above

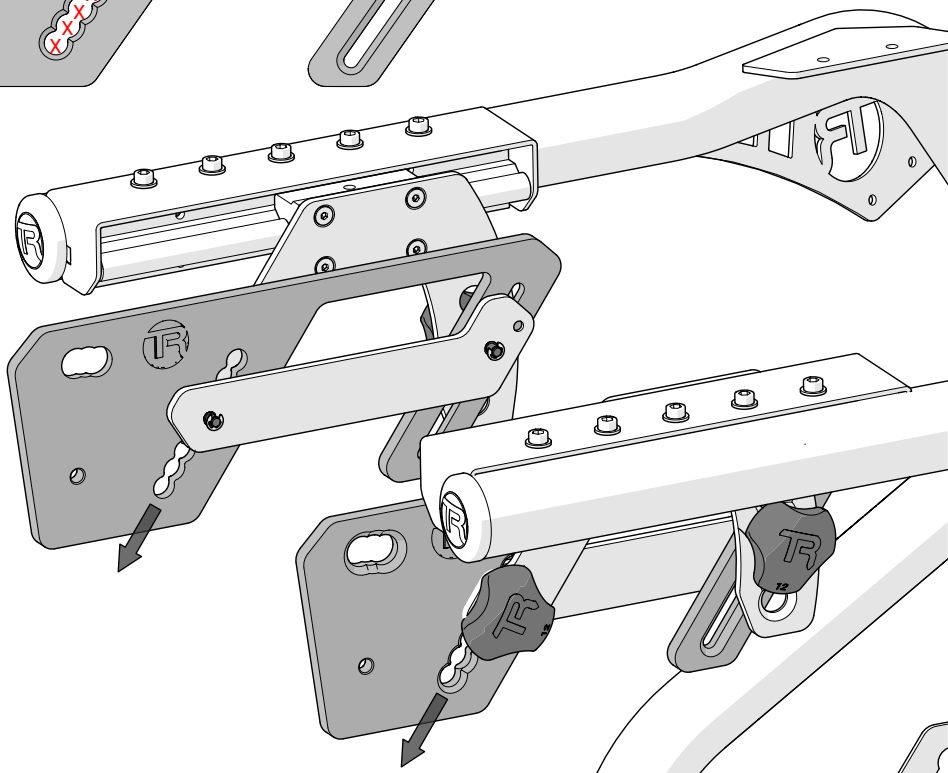

b

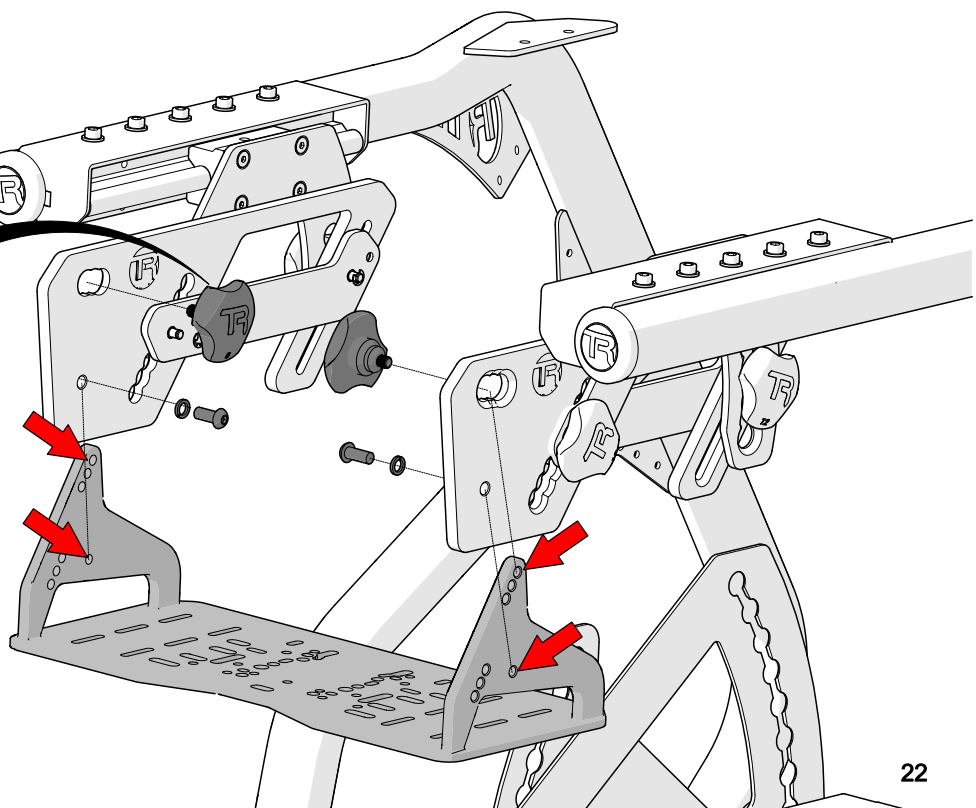
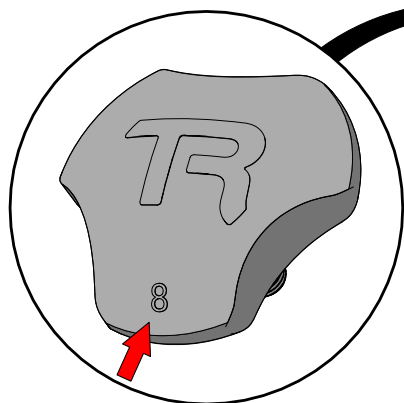

SKIP TO PAGE 34

OPTION 2: Direct Drive Wheel Mount

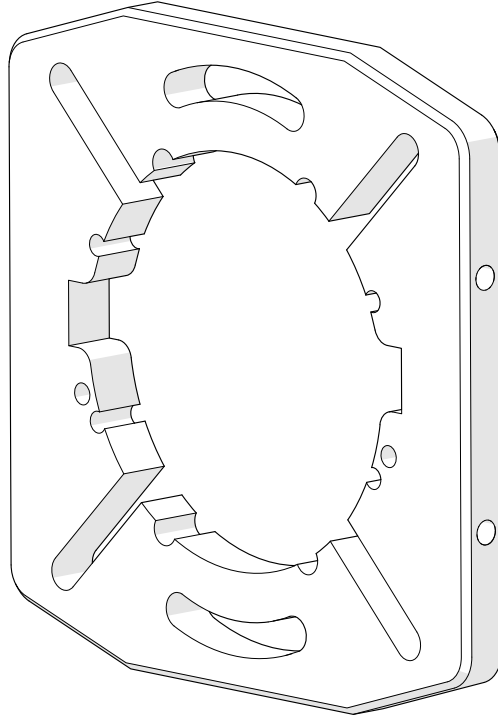

Part #	Image	Description	QTY	Check
BOX #: TR-TR8-SING				
WM-DD		Wheel Mount, Direct Drive	1	
SH-M5-10		Screw (Button), M5x10	2	
SH-M8-20		Screw (Button), M8x20	4	
SH-M8-25		Screw (Button), M8x25	4	
WF-M5		Washer (Flat), M5	2	
WF-M8		Washer (Flat), M8	4	

* **NOTE:** Extra hardware may be included as spare parts

TR-80-NWMDD

11



TRX-WLB x1



TRX-WRB x1



SB-M6-10 x8

NOTE: Some screws and washers come pre-installed. These will be part of the parts list and will need to be removed and reattached according to the instructions.



a

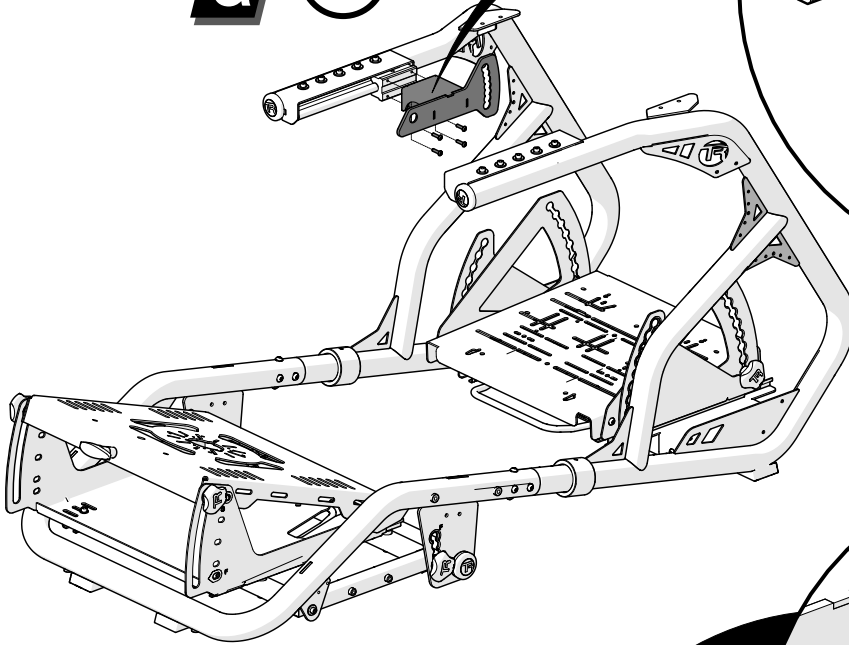
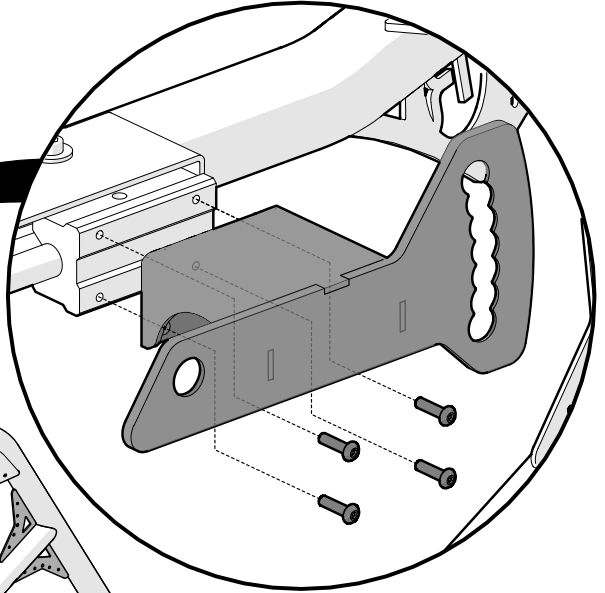

b

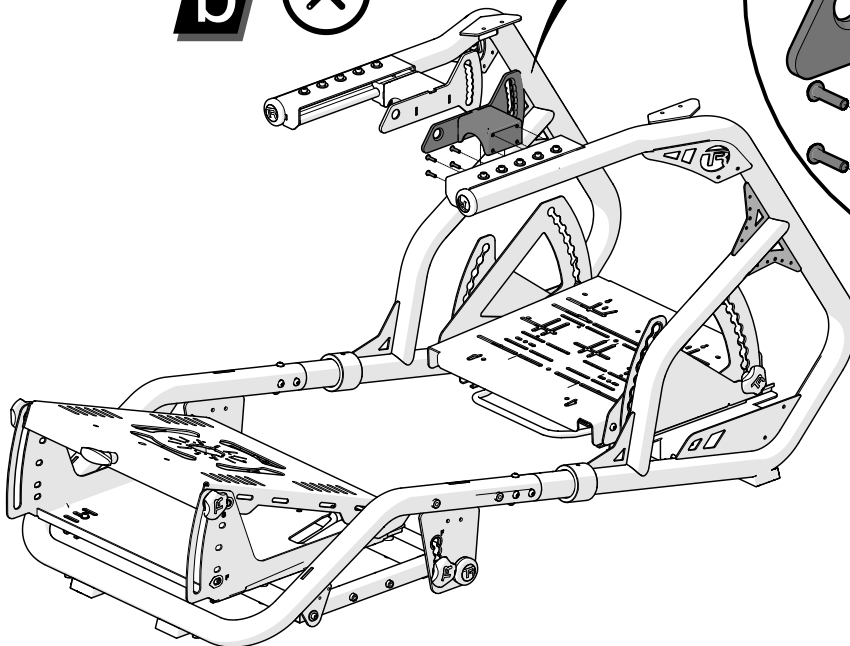
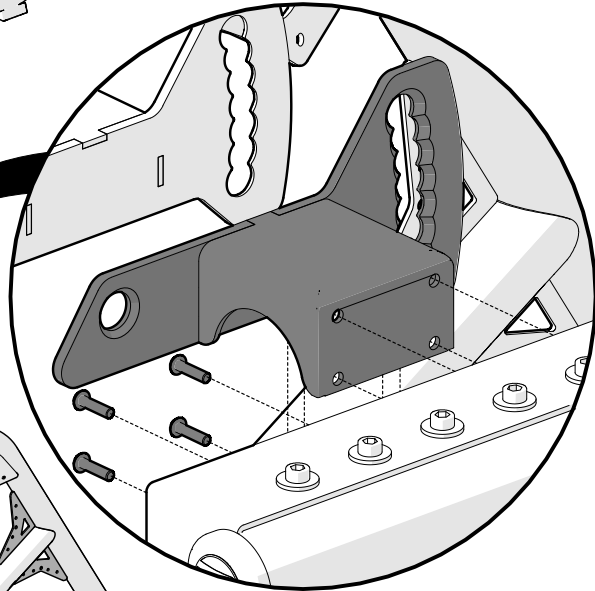

12

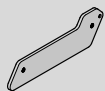

TRX-WLAP x1



TRX-WRAP x1



TRX-SWRL x1



SF-M6-10 x2

NOTE: TR-SWRL is an assembly rod used to maintain alignment of your wheel mount. It will not add rigidity. This part can be removed if it impedes with your wheel base.



NOTE: Use TR-SWRL for wheel bases 240mm or less in length (from mounting surface to back surface).

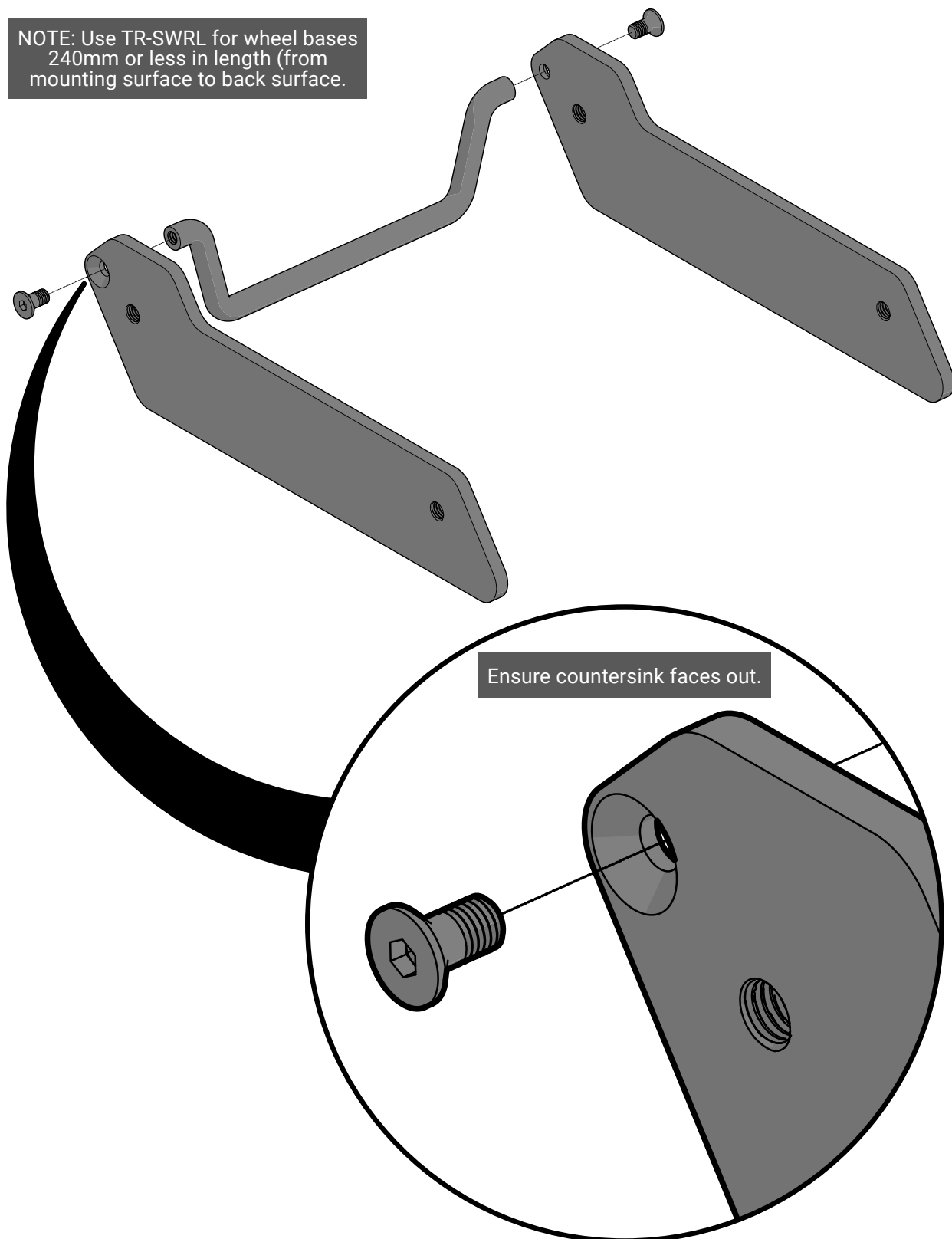

Ensure countersink faces out.

13



TRX-SWP x2



TRX-KNOB12 x2



TRX-KNOB14 x2



RC-M5 x1

a

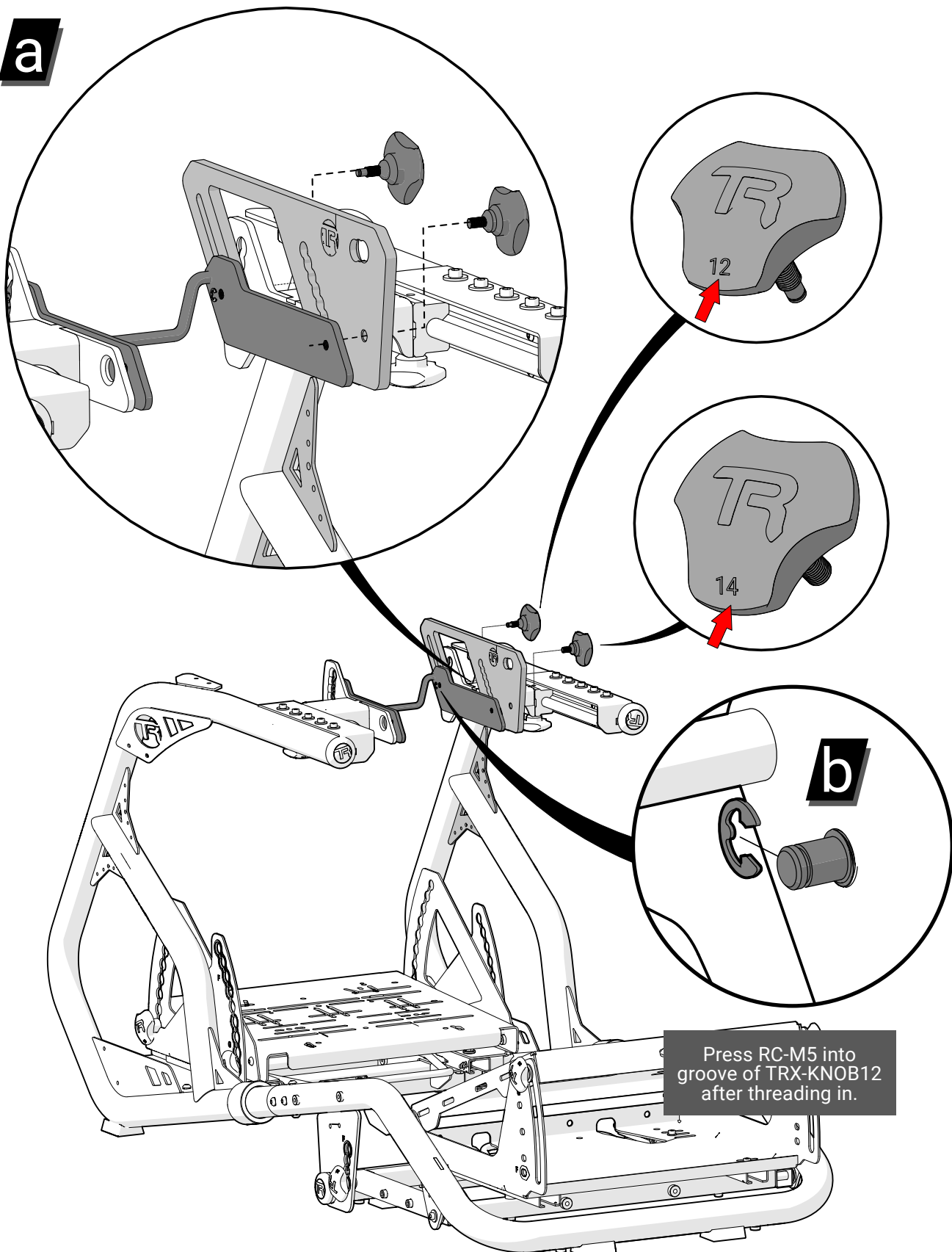

14



TRX-SWP x2



TRX-KNOB12 x2



TRX-KNOB14 x2



RC-M5 x1

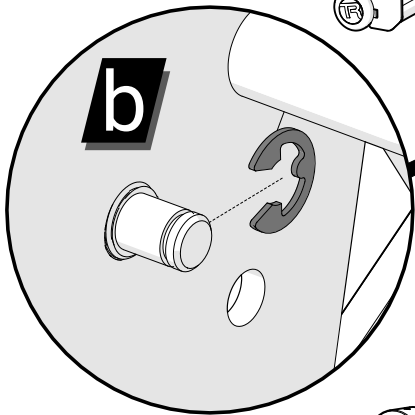
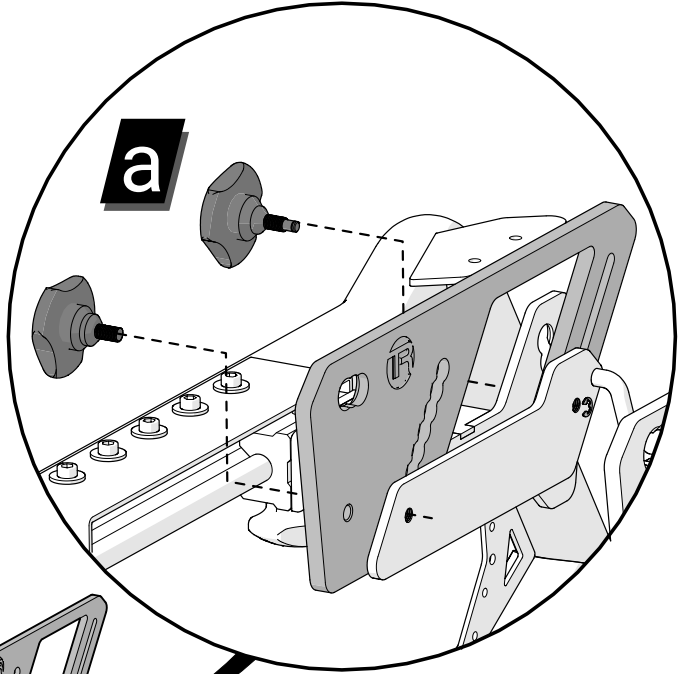
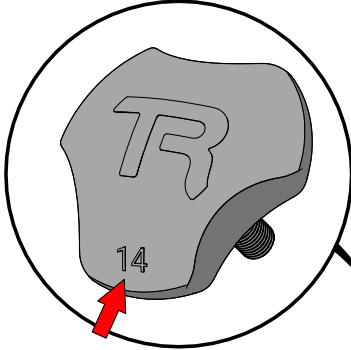
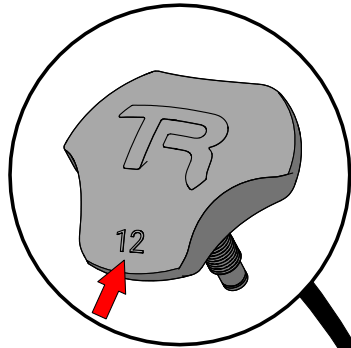

Press retaining clips into groove of TRX-KNOB12 after threading in.

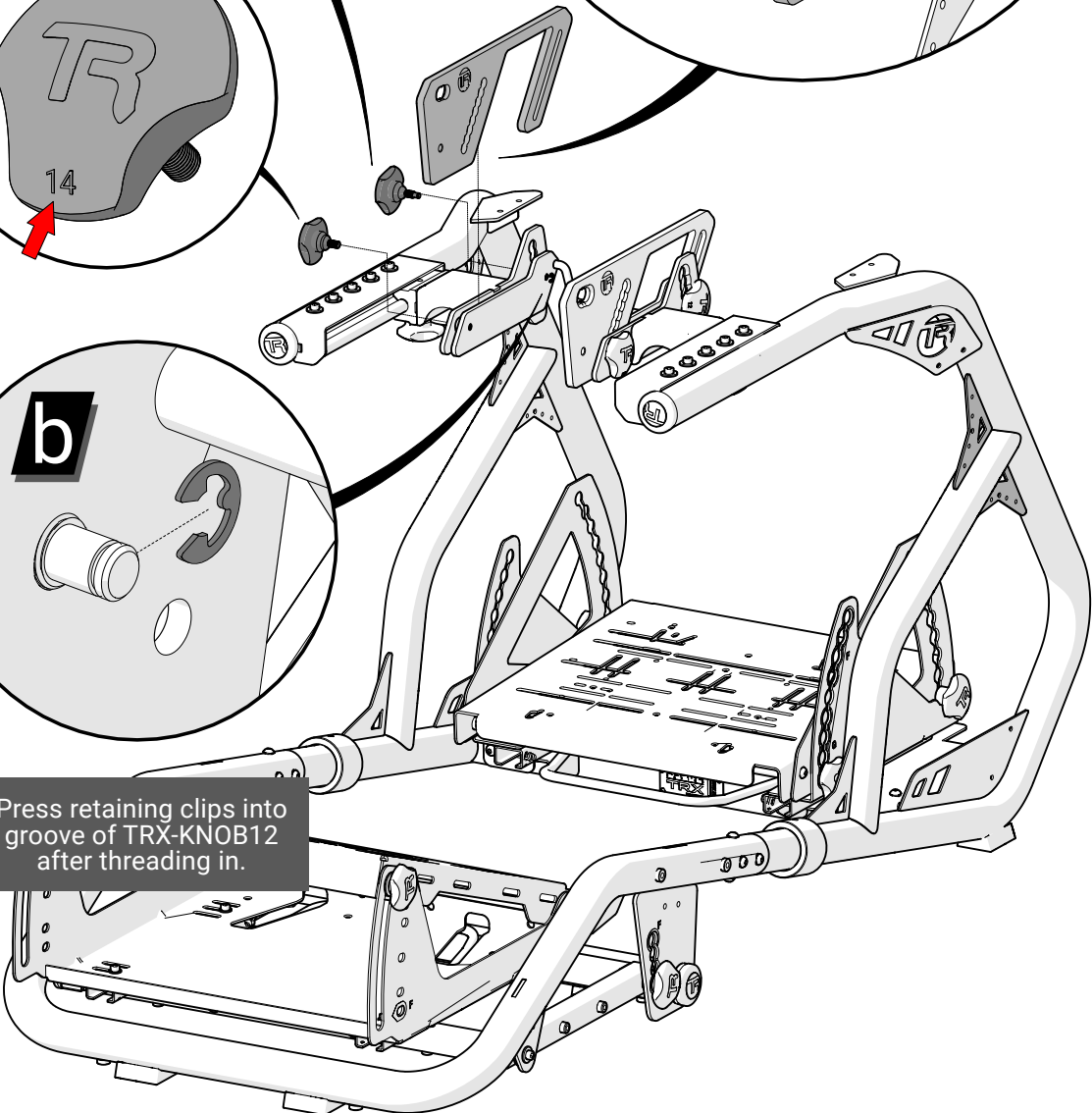

15



WM-DD x1



TRX-BUSH5 x4

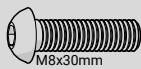

SB-M8-30 x2



WL-M8 x2



WF-M8 x2



TRX-KNOB14 x2

NOTE: FOR FRONT MOUNTED DIRECT DRIVE WHEEL BASES

NOTE: Use screws and washers included in the TRX assembly.

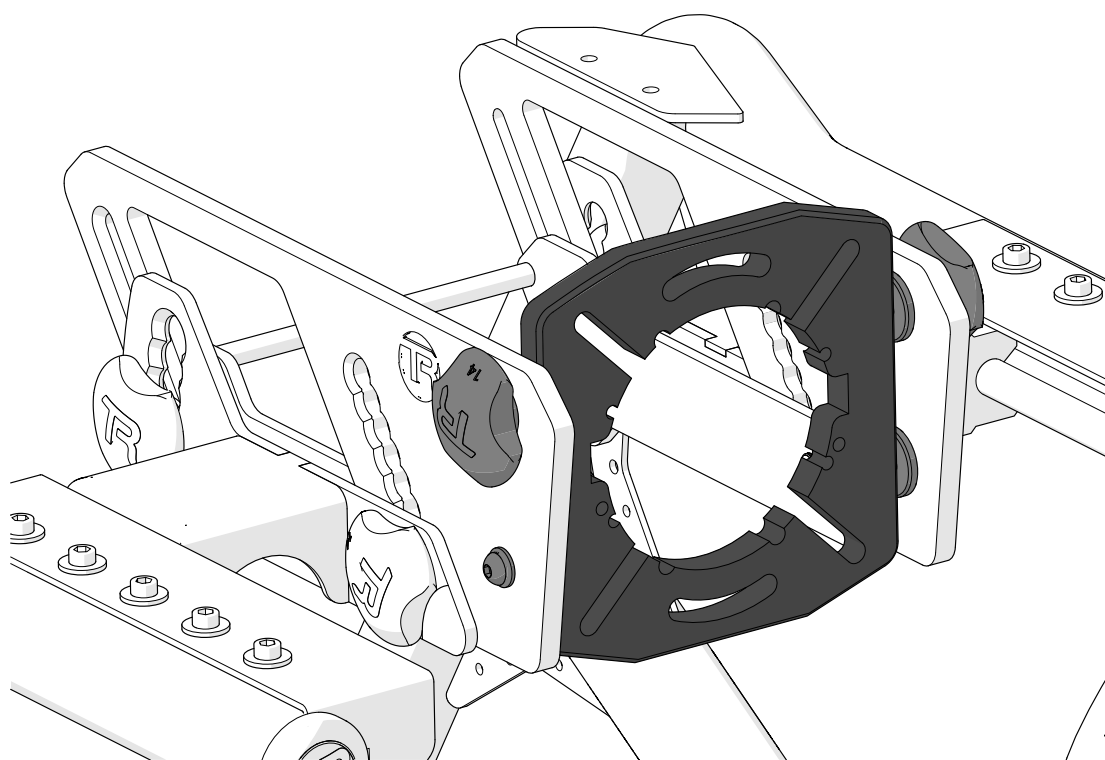
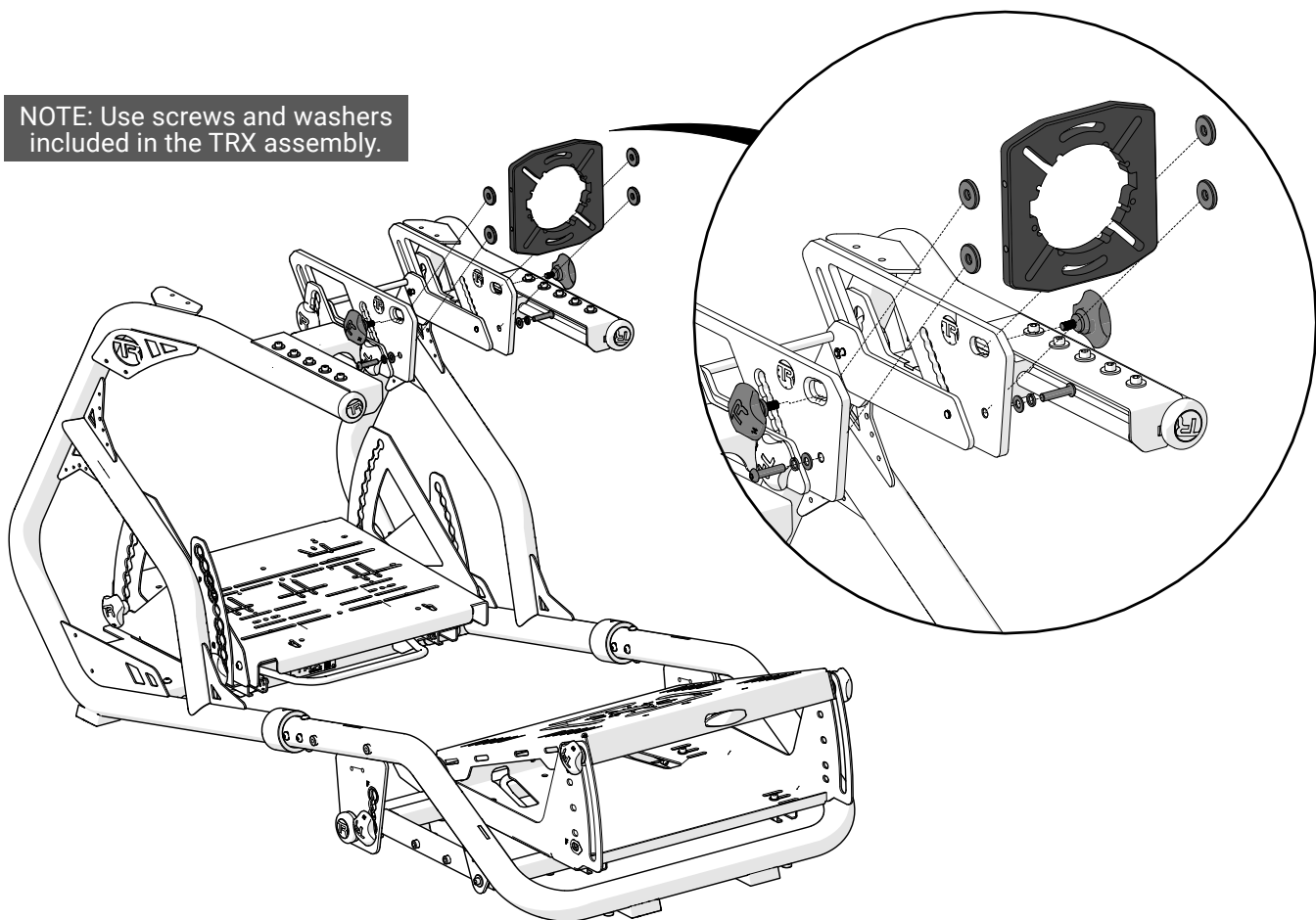

SKIP TO PAGE 34

11



TRX-WLB x1



TRX-WRB x1



SB-M6-10 x8

NOTE: Some screws and washers come pre-installed. These will be part of the parts list and will need to be removed and reattached according to the instructions.



a

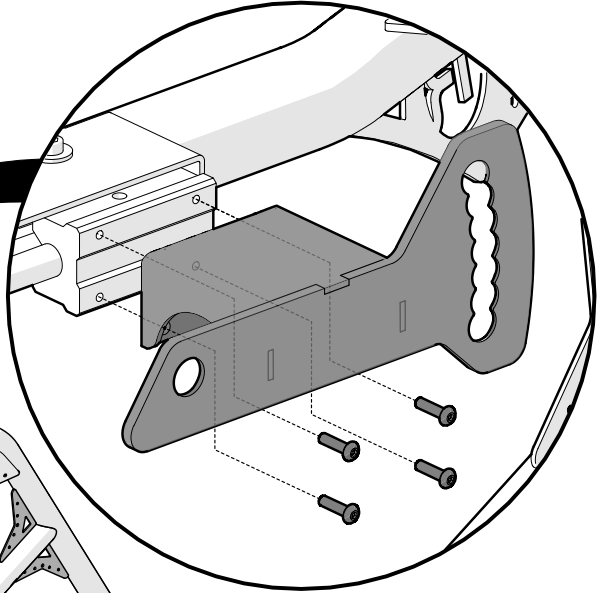

b

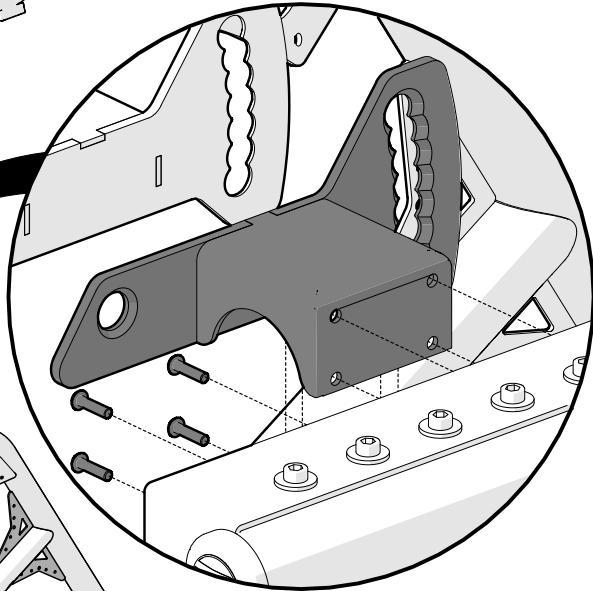

12

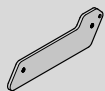

TRX-WLAP x1



TRX-WRAP x1



TRX-SWRL x1



SF-M6-10 x2

NOTE: TR-SWRL is an assembly rod used to maintain alignment of your wheel mount. It will not add rigidity. This part can be removed if it impedes with your wheel base.



NOTE: Use TR-SWRL for wheel bases 240mm or less in length (from mounting surface to back surface).

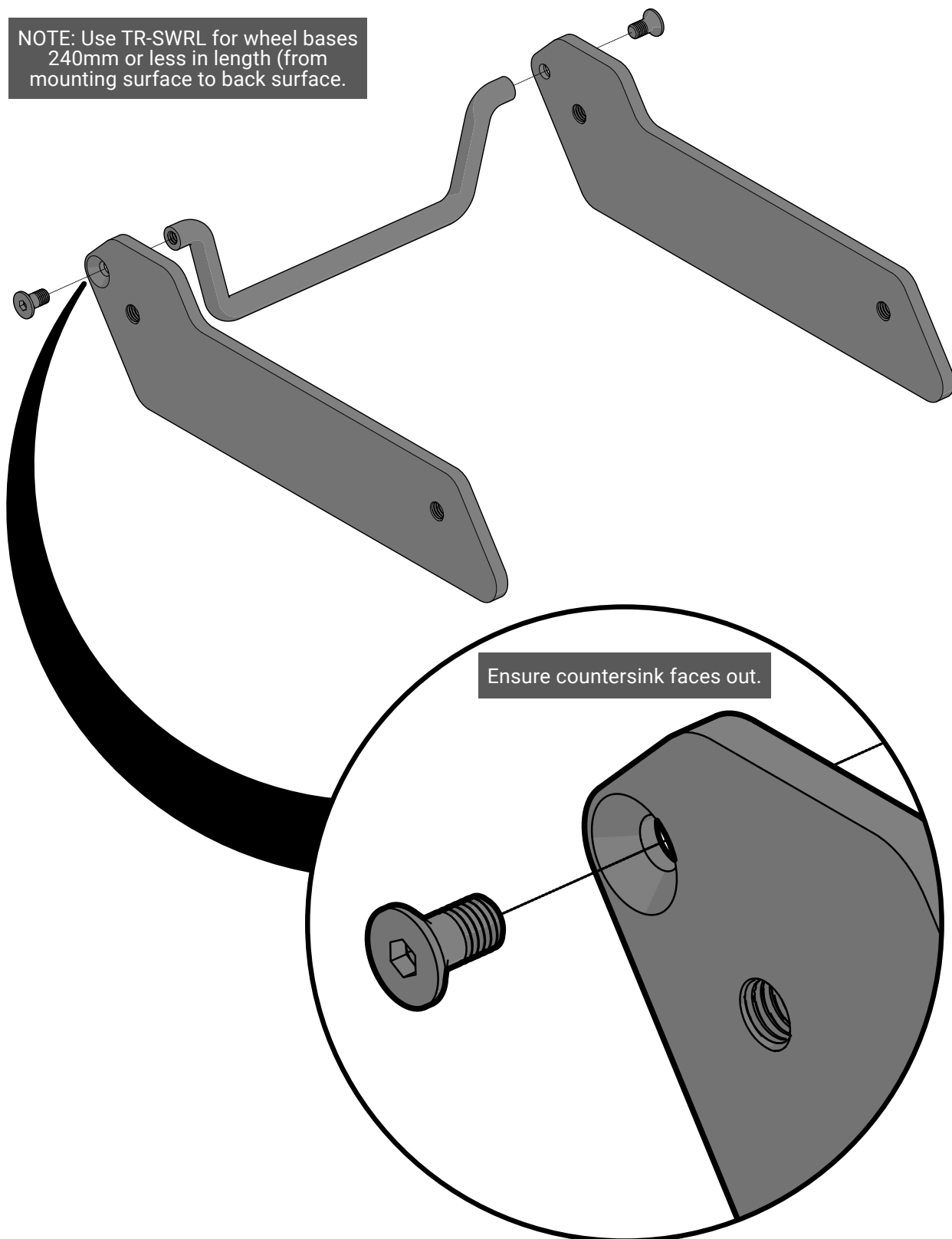

13



TRX-SWP x2



TRX-KNOB12 x2



TRX-KNOB14 x2



RC-M5 x1

a

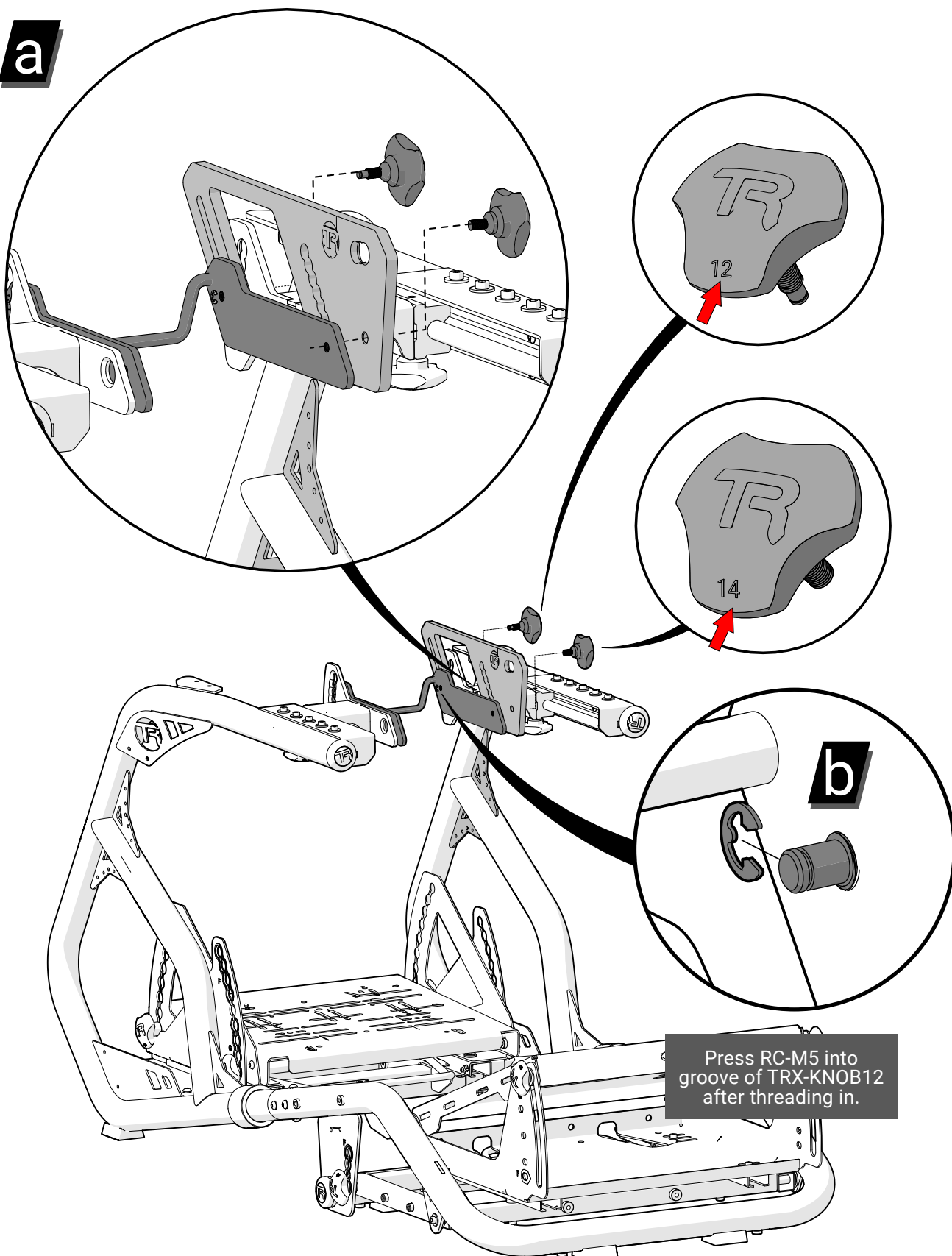

Press RC-M5 into groove of TRX-KNOB12 after threading in.

14



TRX-SWP x2



TRX-KNOB12 x2



TRX-KNOB14 x2



RC-M5 x1

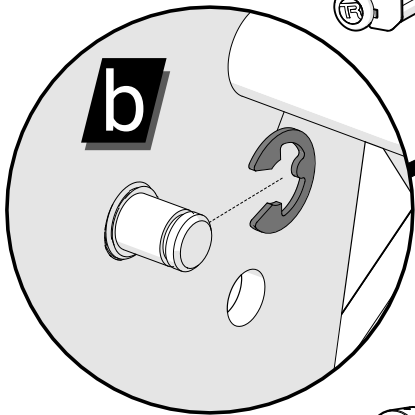
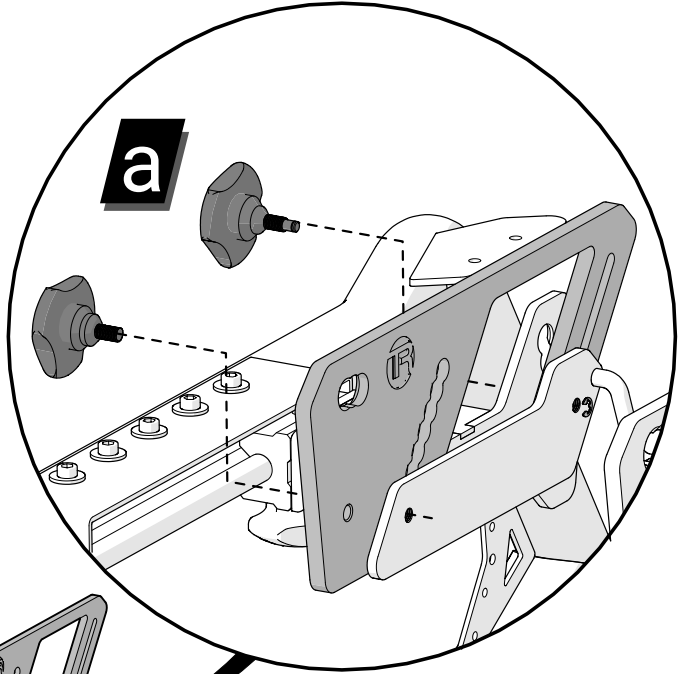
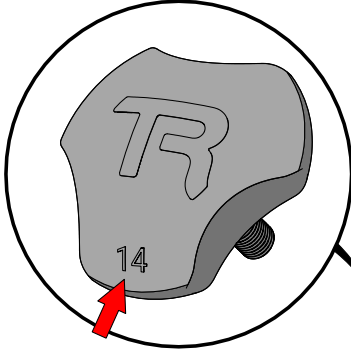
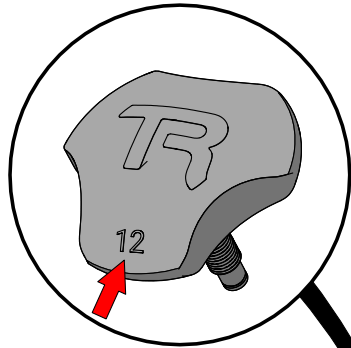

Press retaining clips into groove of TRX-KNOB12 after threading in.

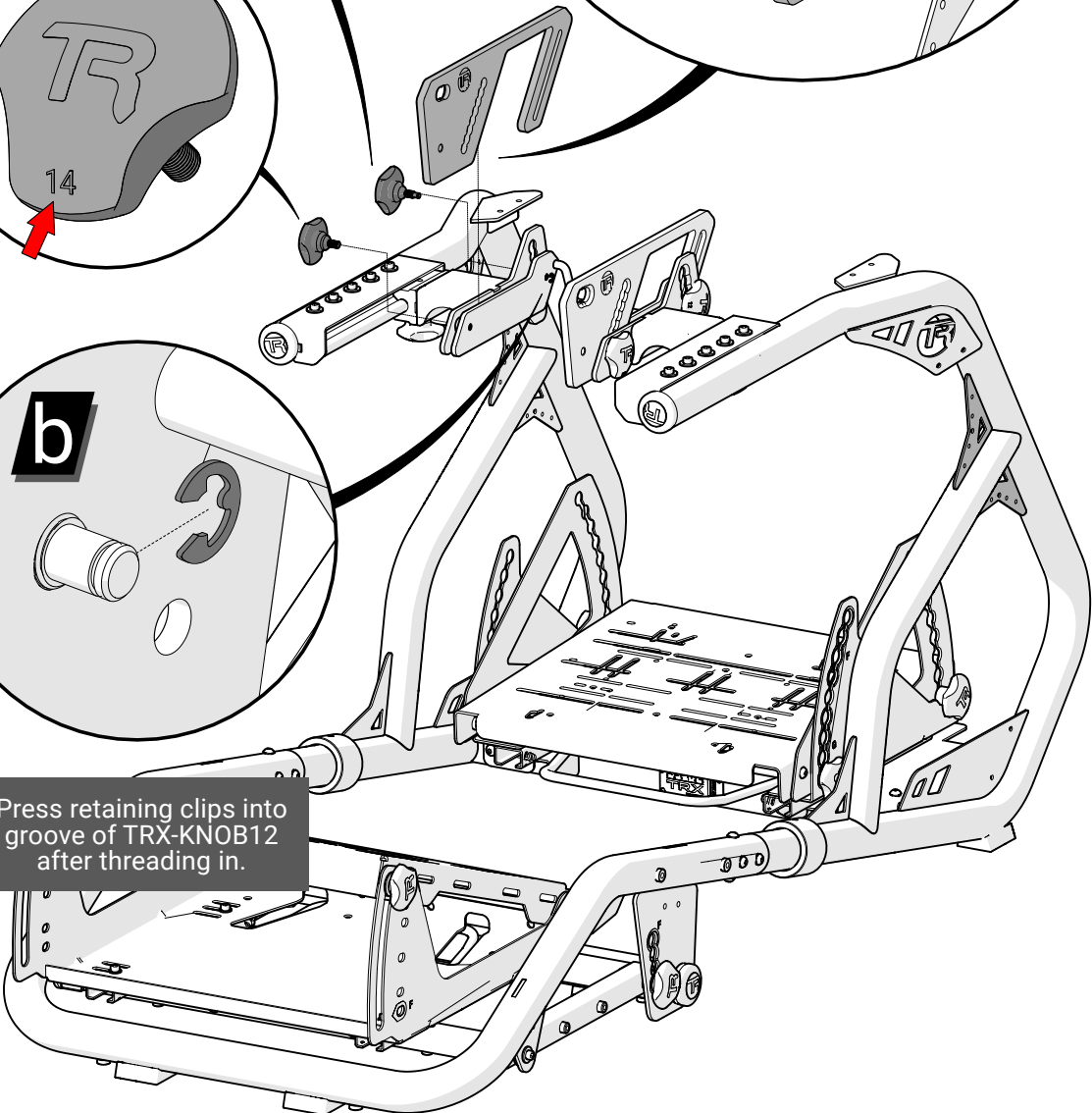

15



TRX-BUSH10 x4

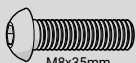

SB-M8-35 x2



WL-M8 x2



WF-M8 x2



TRX-KNOB19 x2

NOTE: FOR FANATEC DD1 / DD2

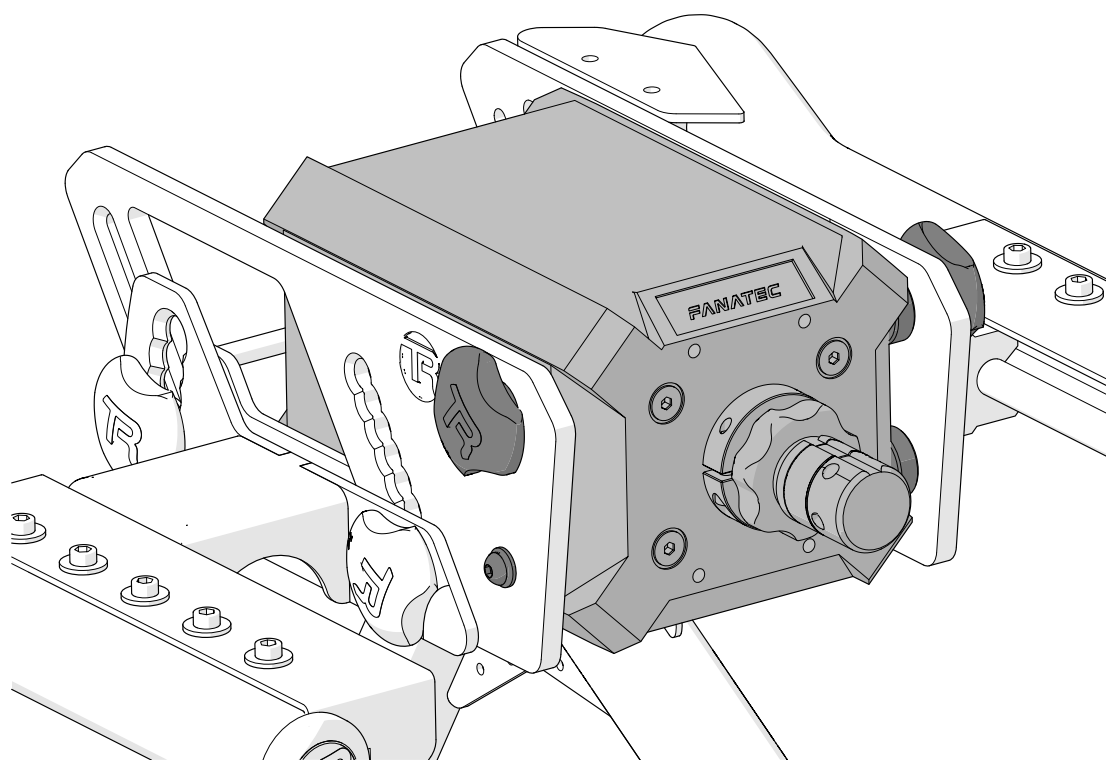
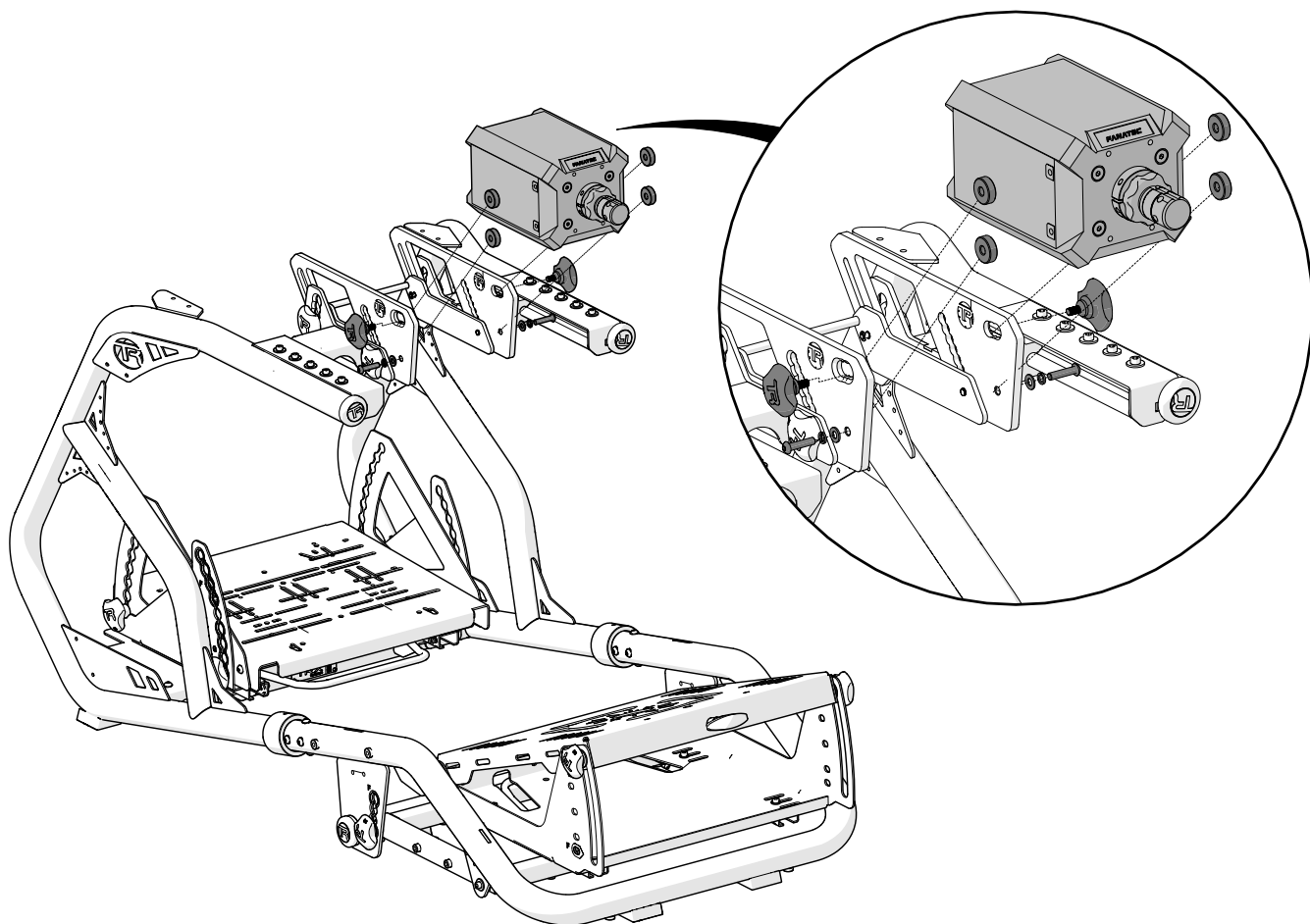

SKIP TO PAGE 34

11



TRX-WLB x1



TRX-WRB x1



SB-M6-10 x8

NOTE: Some screws and washers come pre-installed. These will be part of the parts list and will need to be removed and reattached according to the instructions.



a

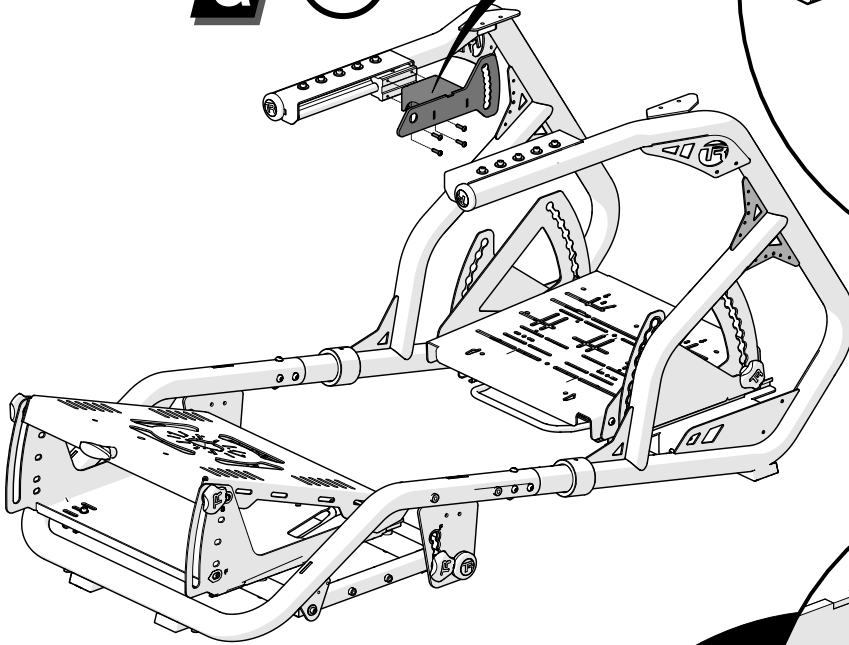
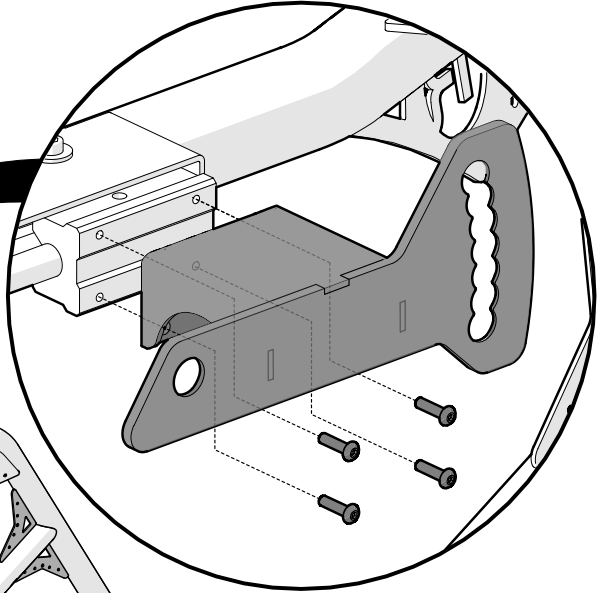

b

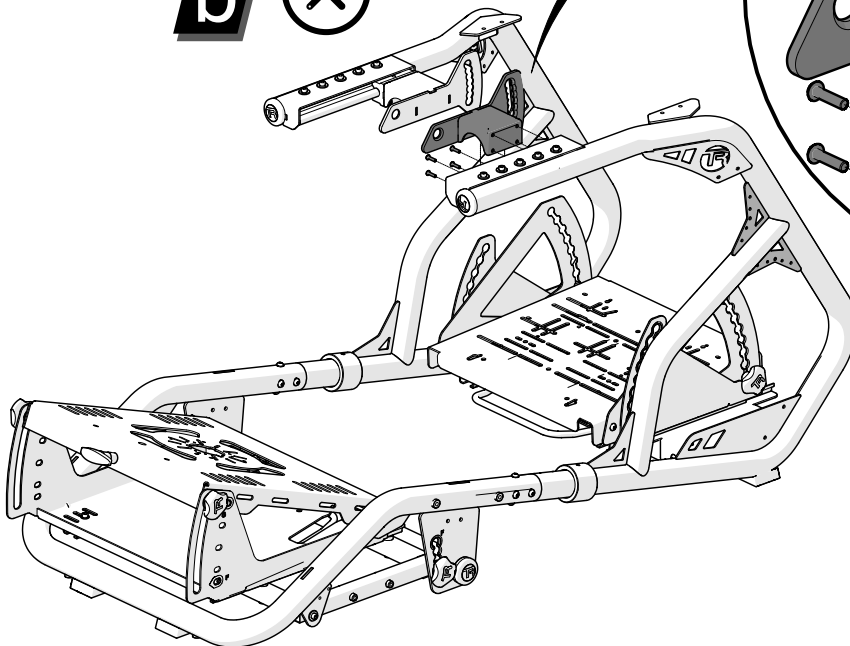
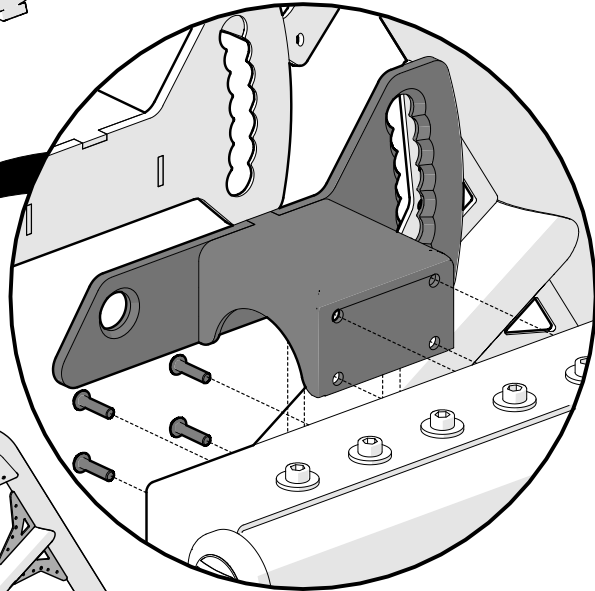

12

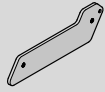

TRX-WLAP x1



TRX-WRAP x1



TRX-SWRL x1



SF-M6-10 x2

NOTE: TR-SWRL is an assembly rod used to maintain alignment of your wheel mount. It will not add rigidity. This part can be removed if it impedes with your wheel base.



NOTE: Use TR-SWRL for wheel bases 240mm or less in length (from mounting surface to back surface).

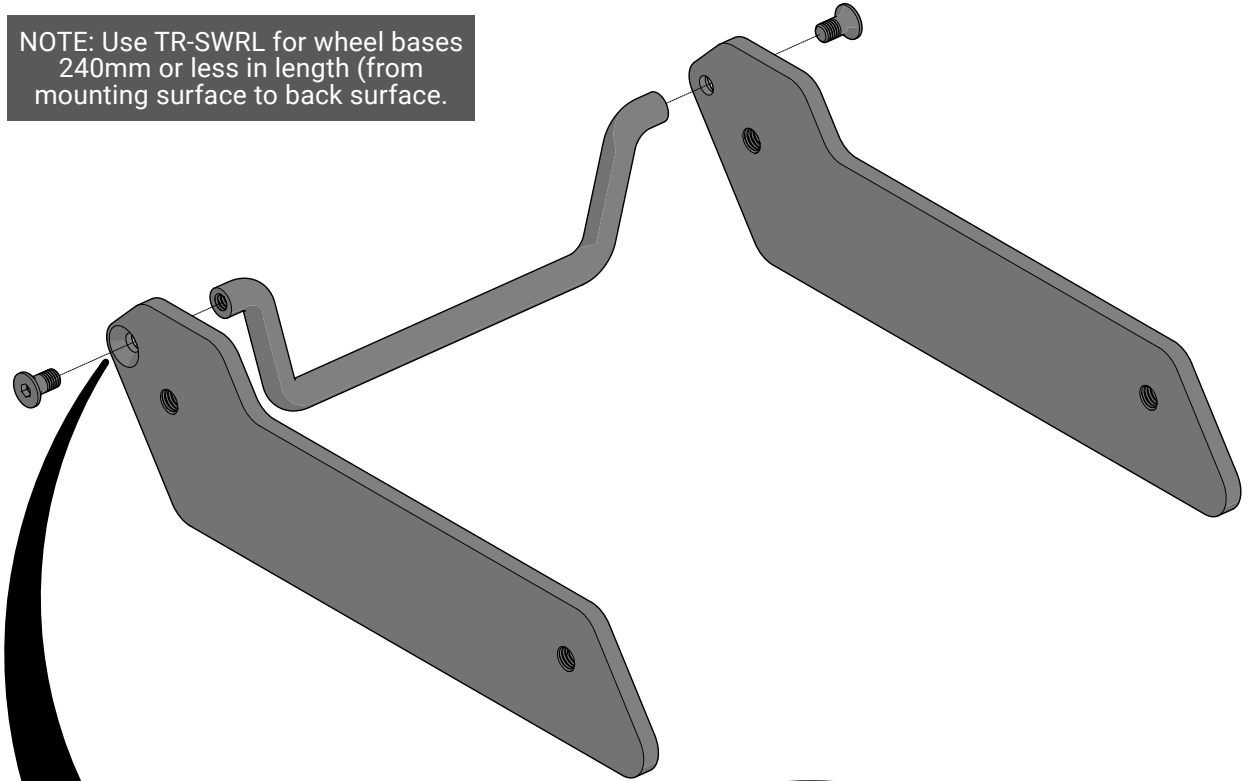

Ensure countersink faces out.

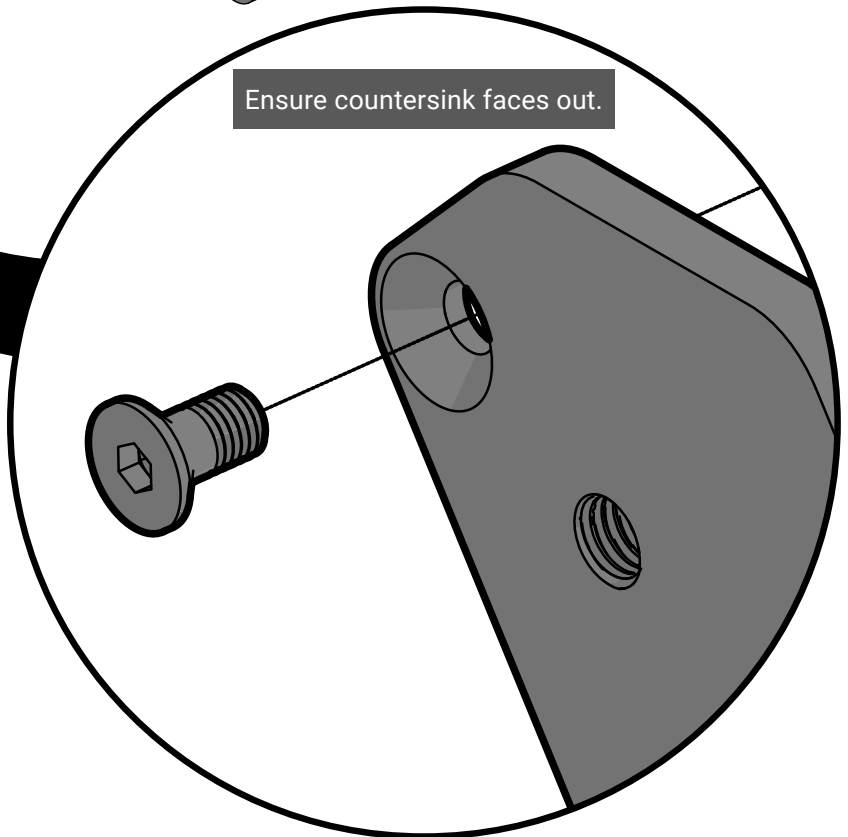

13



TRX-SWP x2



TRX-KNOB12 x2



TRX-KNOB14 x2



RC-M5 x1

a

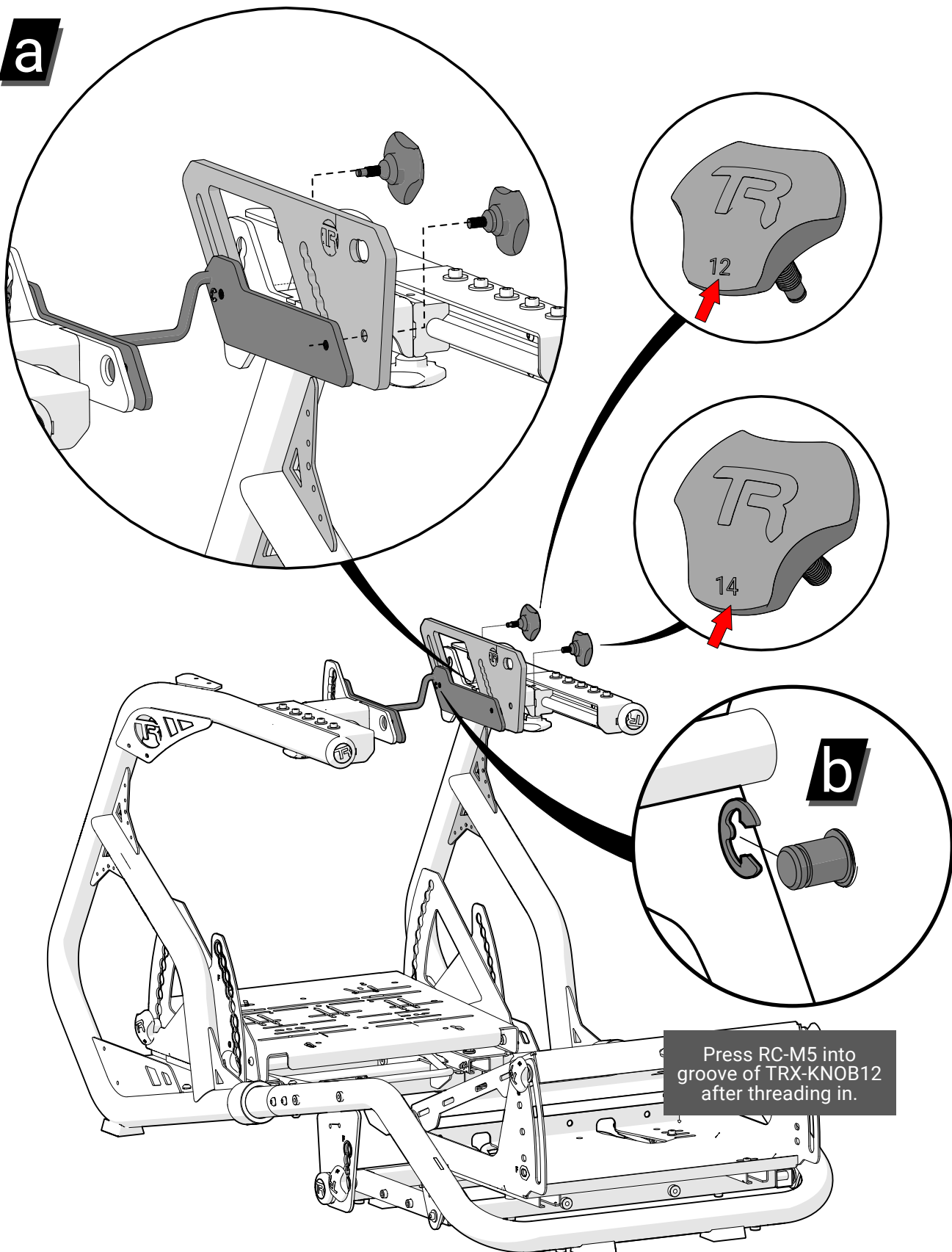

Press RC-M5 into groove of TRX-KNOB12 after threading in.

14



TRX-SWP x2



TRX-KNOB12 x2



TRX-KNOB14 x2



RC-M5 x1

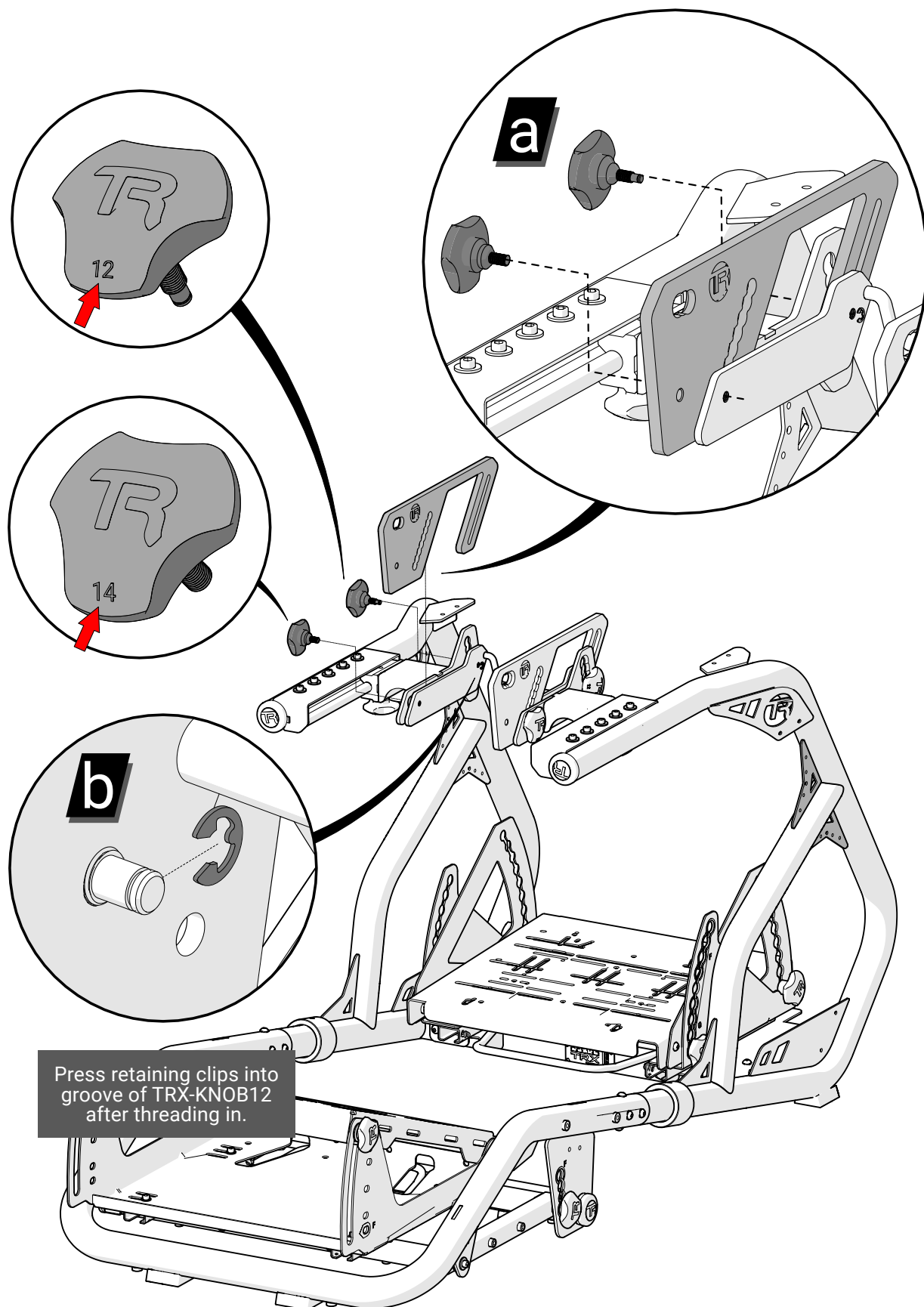

15

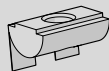

NS-M8 x8

NOTE: FOR FANATEC CSL DD

NOTE: Replace T-nuts (M6) included with CSL DD base with ones included with TRX (M8)

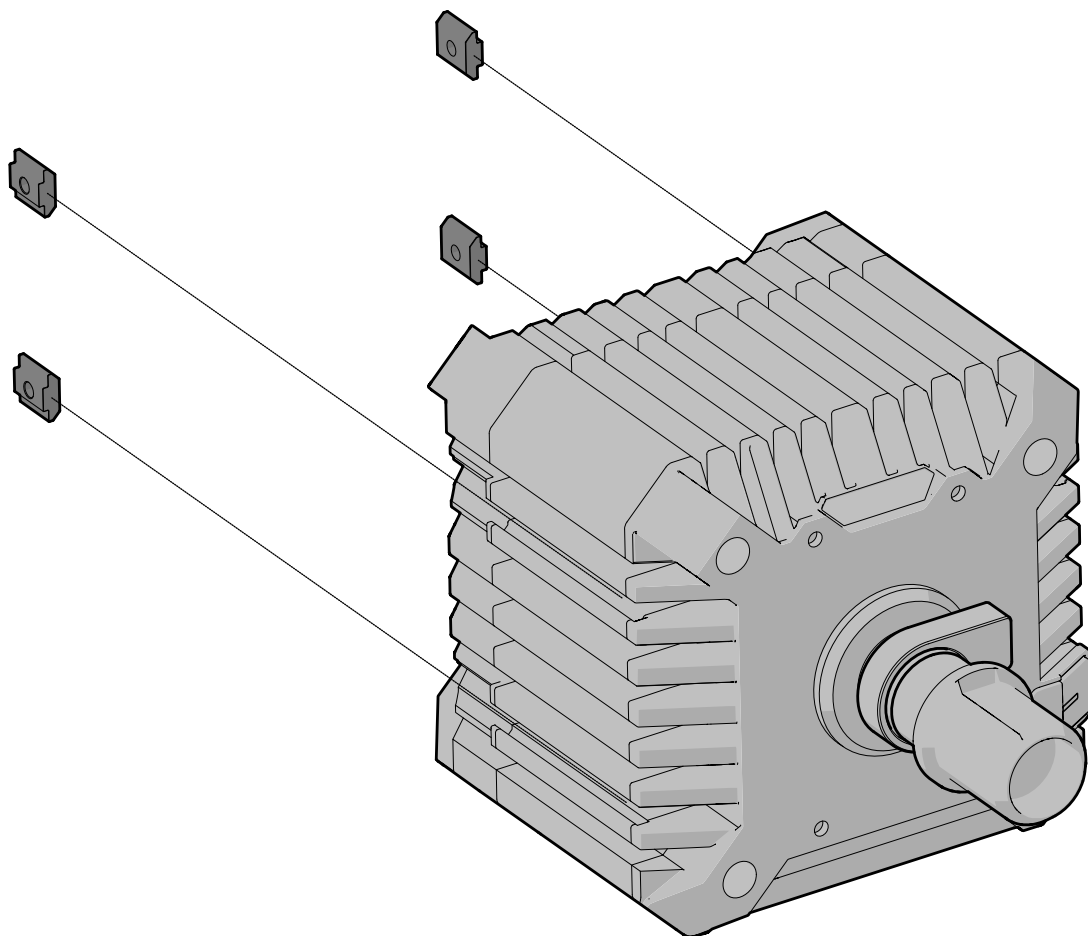

16



TRX-BUSH15 x4

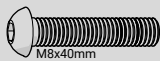

SH-M8-40 x2



WL-M8 x2



WF-M8 x2



TRX-KNOB24 x2

NOTE: FOR FANATEC CSL DD

OPTION 4

NOTE: Use screws and washers included in the TRX assembly.

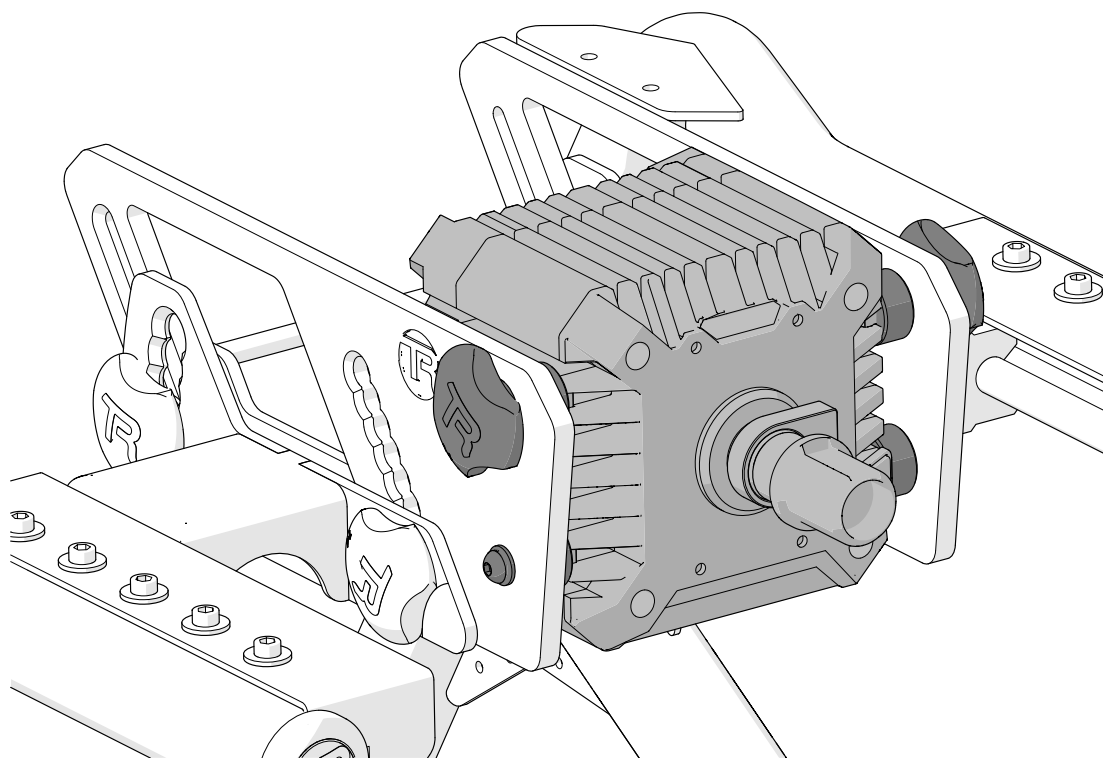
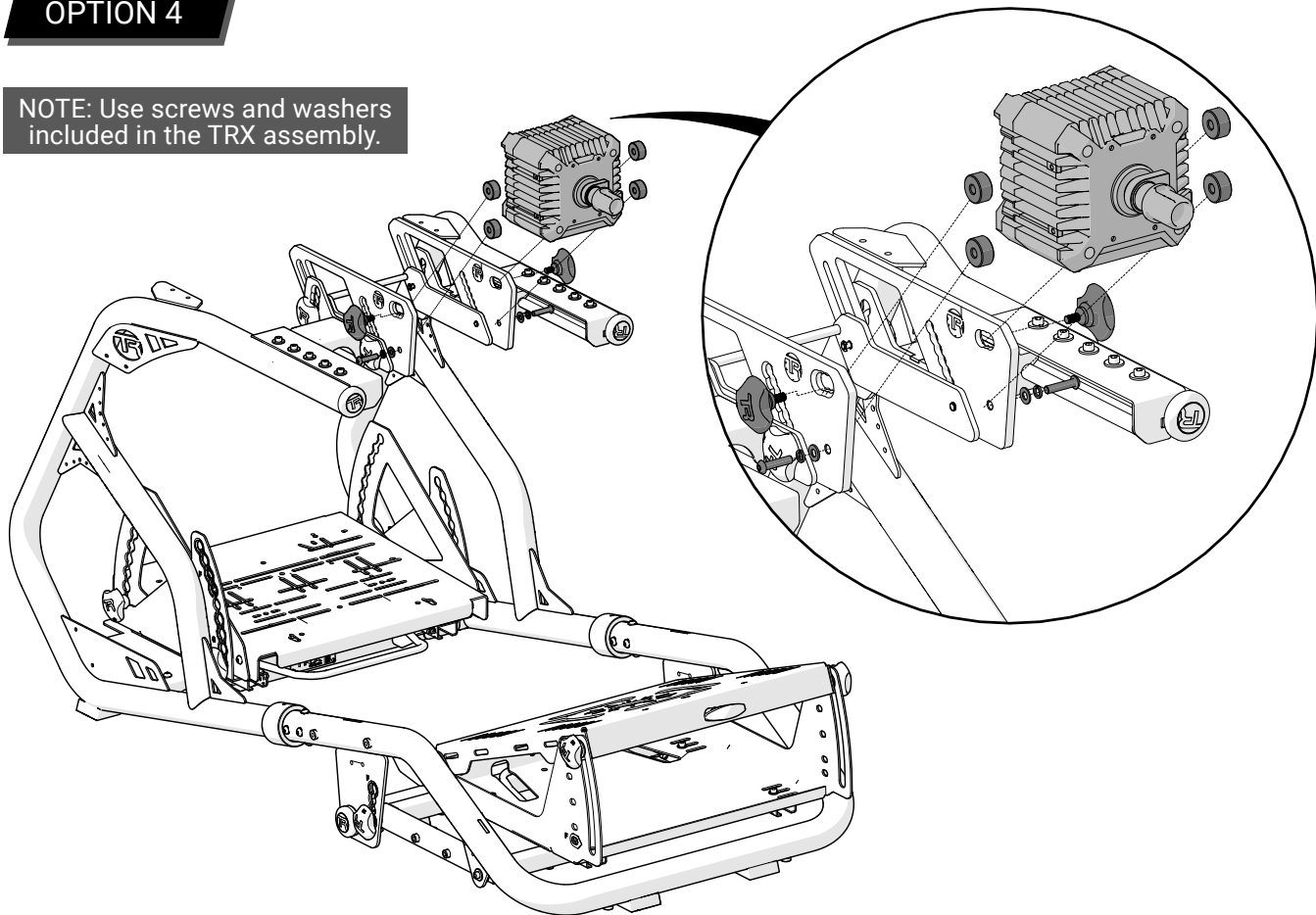

17

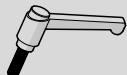

SL-M8-16 x2



TRX-KNOB14 x2

For use with WM-WM6

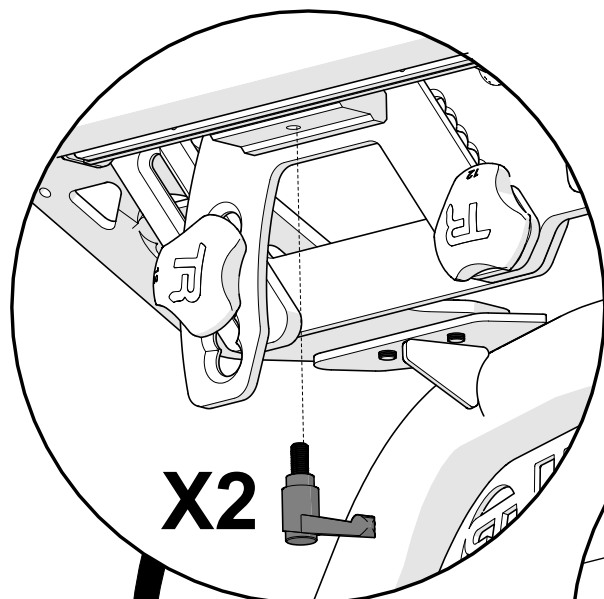

For use with:
WM-WMDD
FANATEC CSL DD
FANATEC DD1/DD2

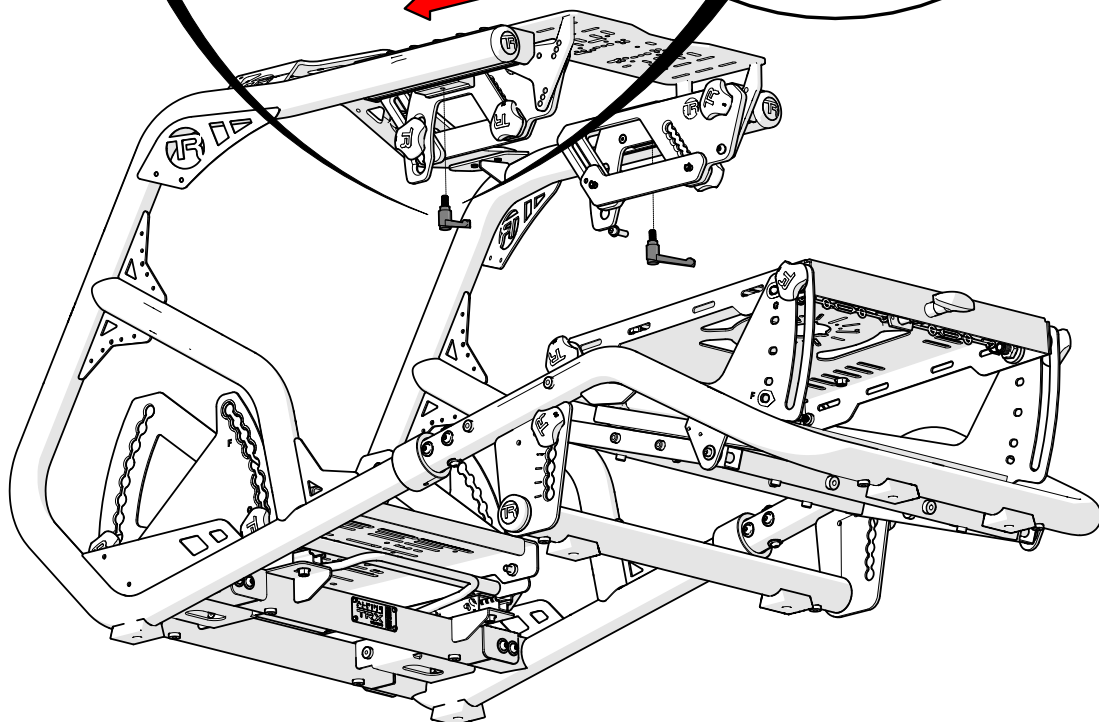
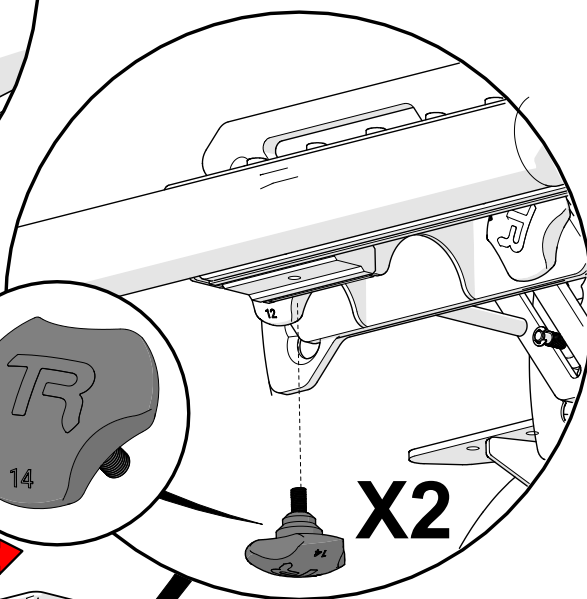
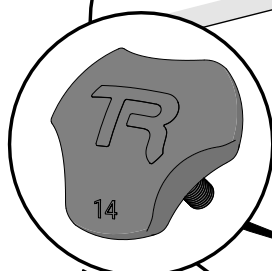

18



TRX-TVSP x1

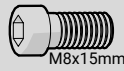

SH-M8-15 x4



WF-M8 x4

NOTE: Some screws and washers come pre-installed. These will be part of the parts list and will need to be removed and reattached according to the instructions.



Keep screws slightly loose until STEP 18

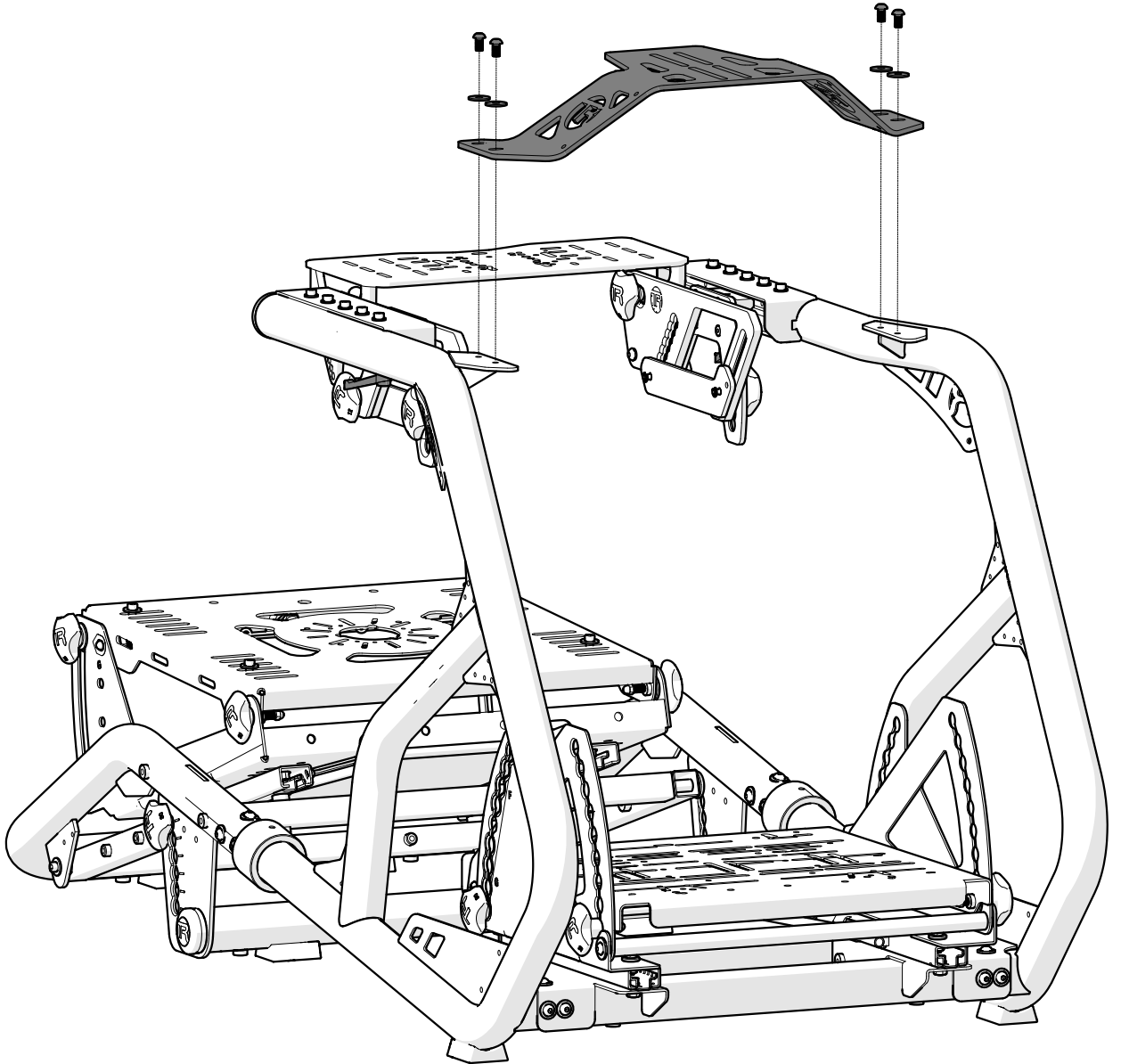

19

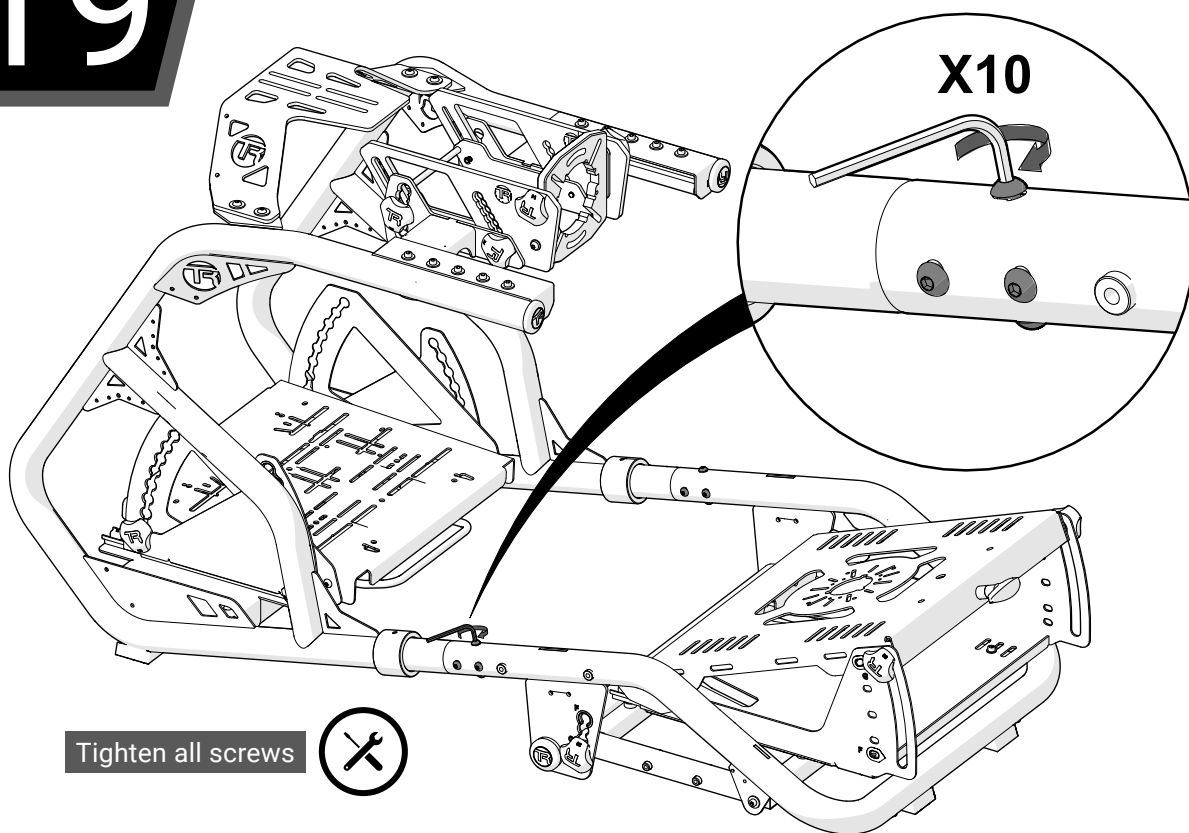

20

Slide collar over the seam between frame tubes and tighten set screws

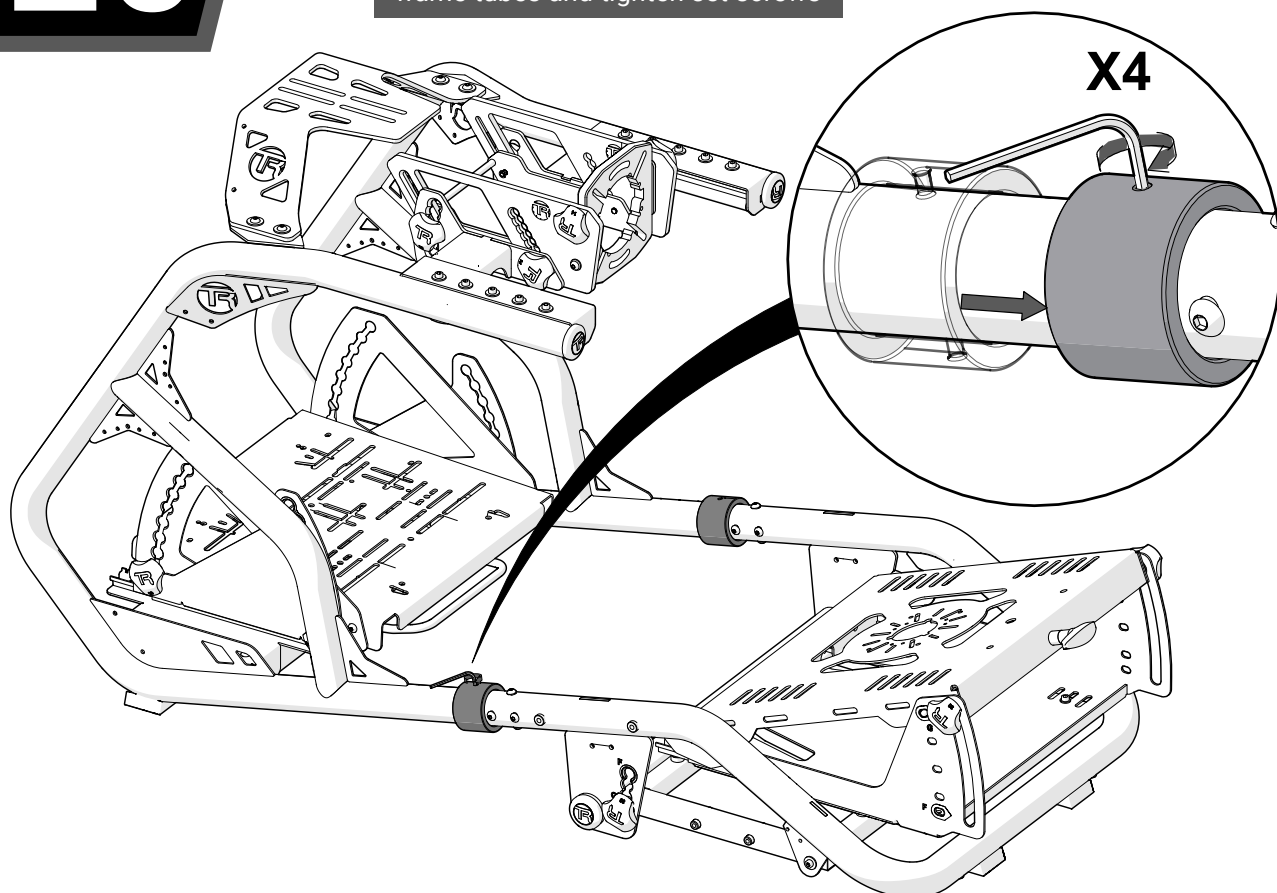

21

a

Visually check that the pedal mount, wheel mount, and support strut are center aligned. Adjust if necessary.

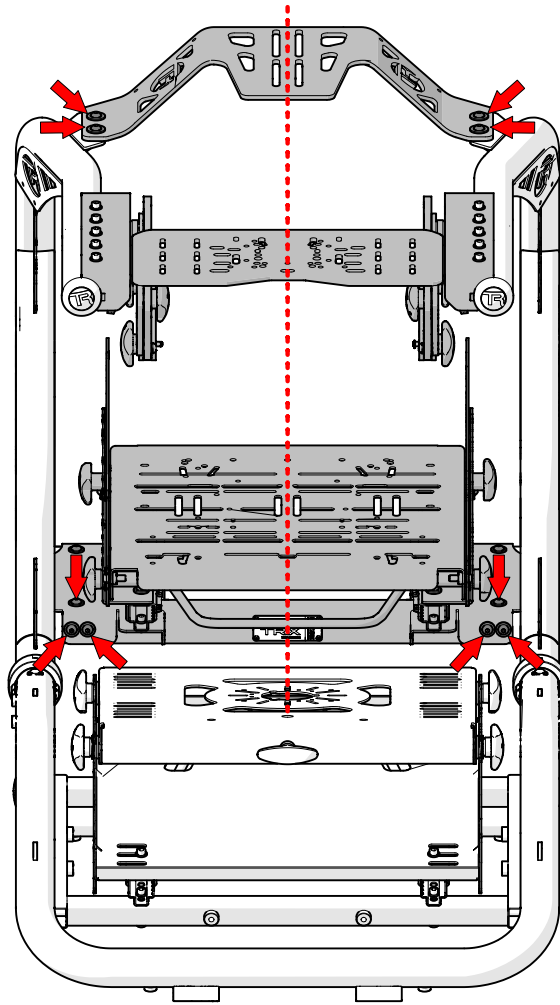

b

Once all parts are centered, tighten all screws indicated by the red arrows.

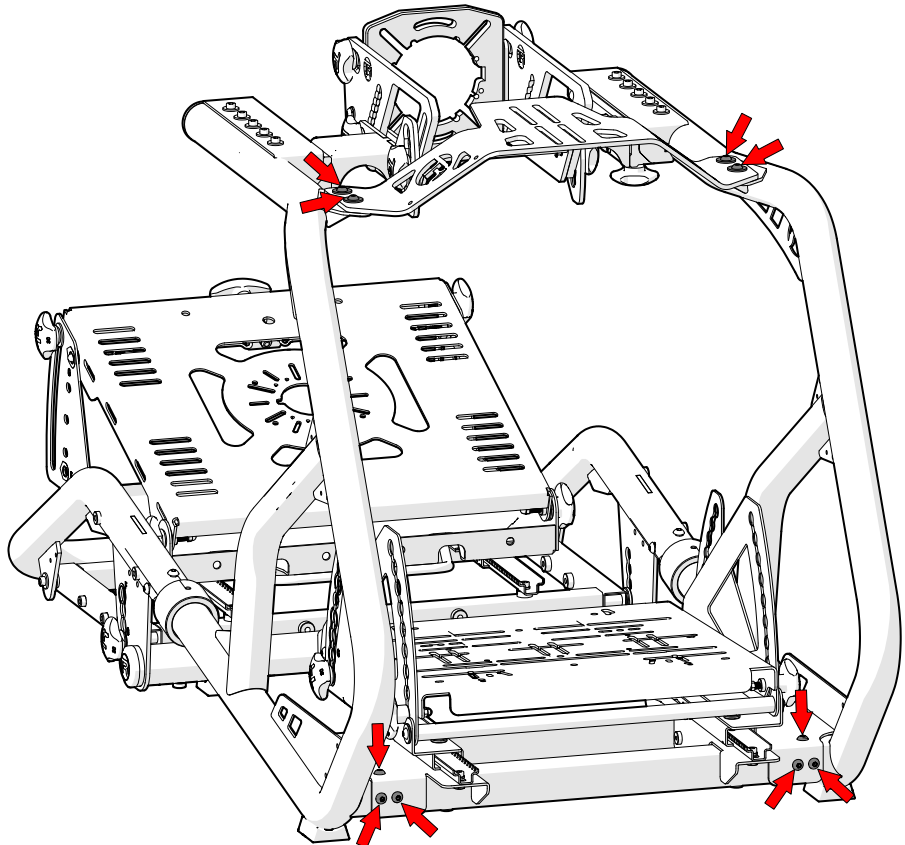

22



TRX-SPL x1



TRX-SPR x1

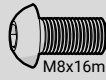

M8x16mm



WF-M8 x4



NF-M8 x4

NOTE: Some screws and washers come pre-installed. These will be part of the parts list and will need to be removed and reattached according to the instructions.

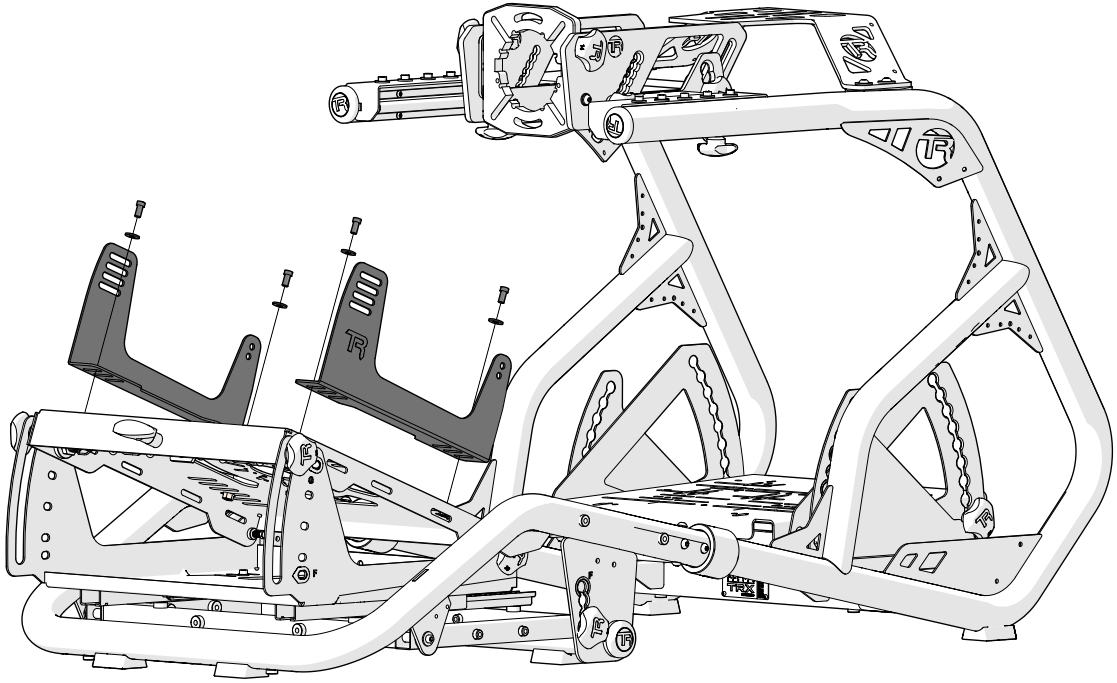

Adjust using slots according to preference



Keep screws loose until STEP 21

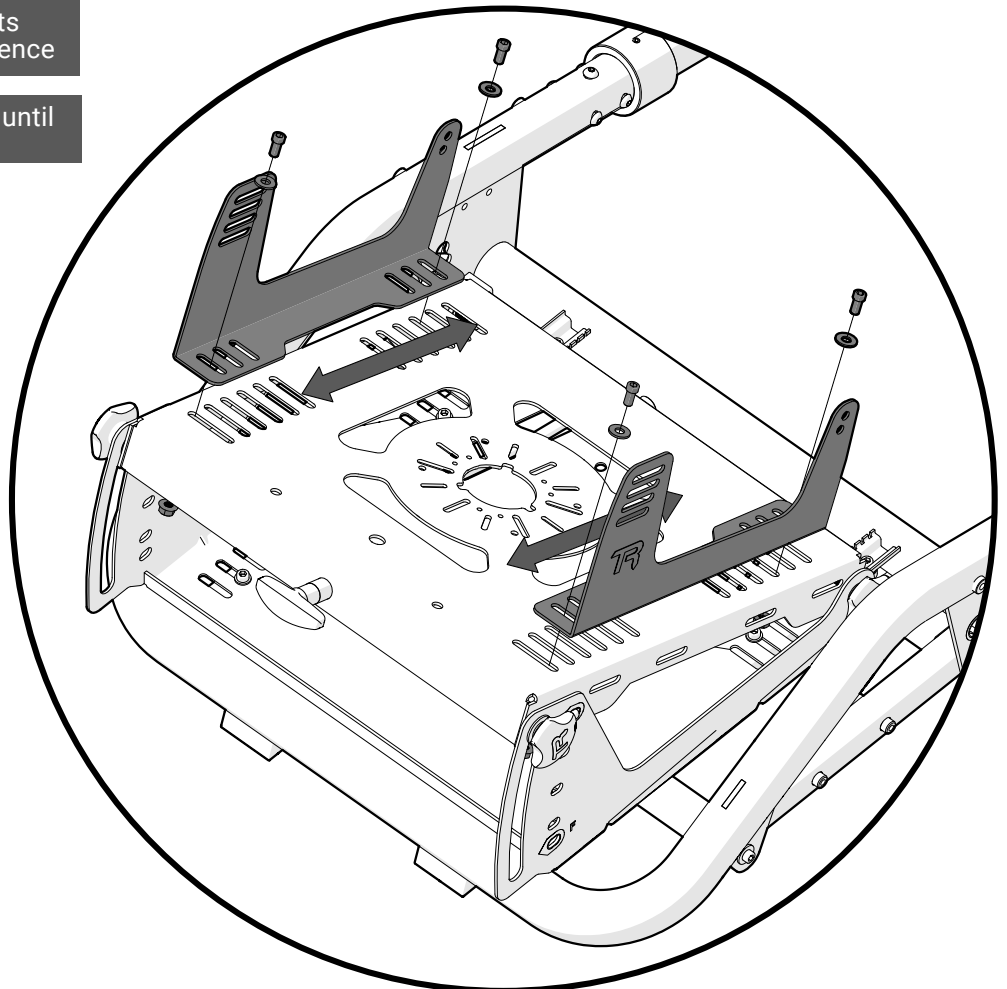

OPTIONAL: TRX Seat

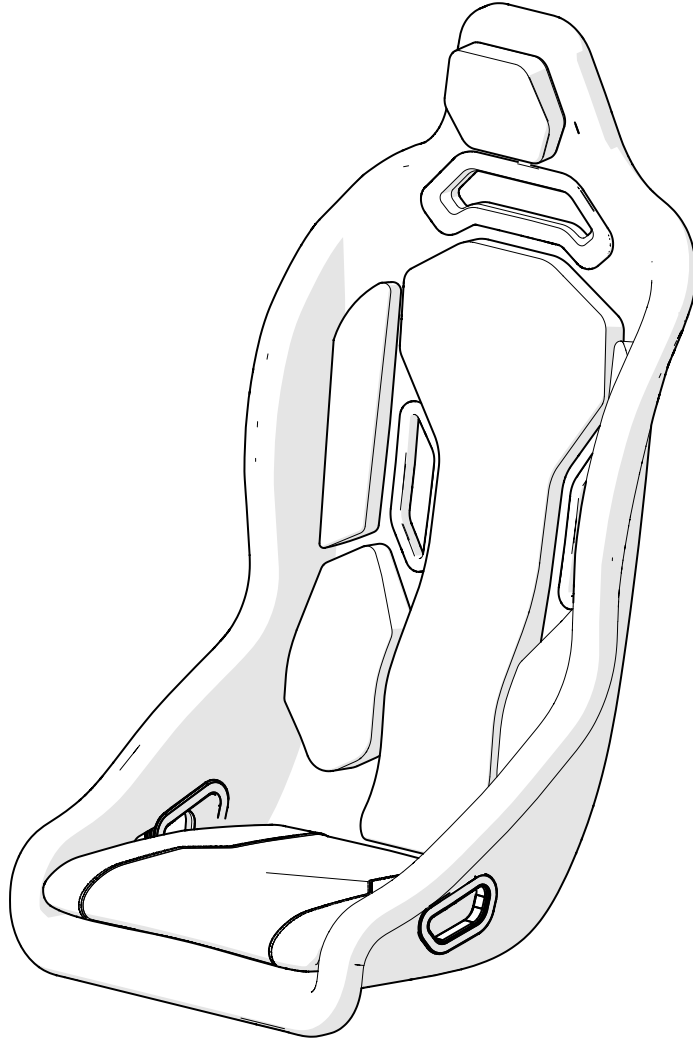

Part #	Image	Description	QTY	Check
	BOX #: TR-TR8-SING			
TRX-S01 TRX-S02 TRX-S03		TRX Seat	1	
SH-M8-25		Screw (Hex), M8x25	4	
WF-M8		Nut (Flange), M8	4	

* **NOTE:** Extra hardware may be included as spare parts

TRX-S01, TRX-S02, TRX-S03

23



SA-TRX x1



SH-M8-25 x4



WF-M8 x4

NOTE: Some screws and washers come pre-installed. These will be part of the parts list and will need to be removed and reattached according to the instructions.



Adjust height and angle using holes according to preference

Install front screws first

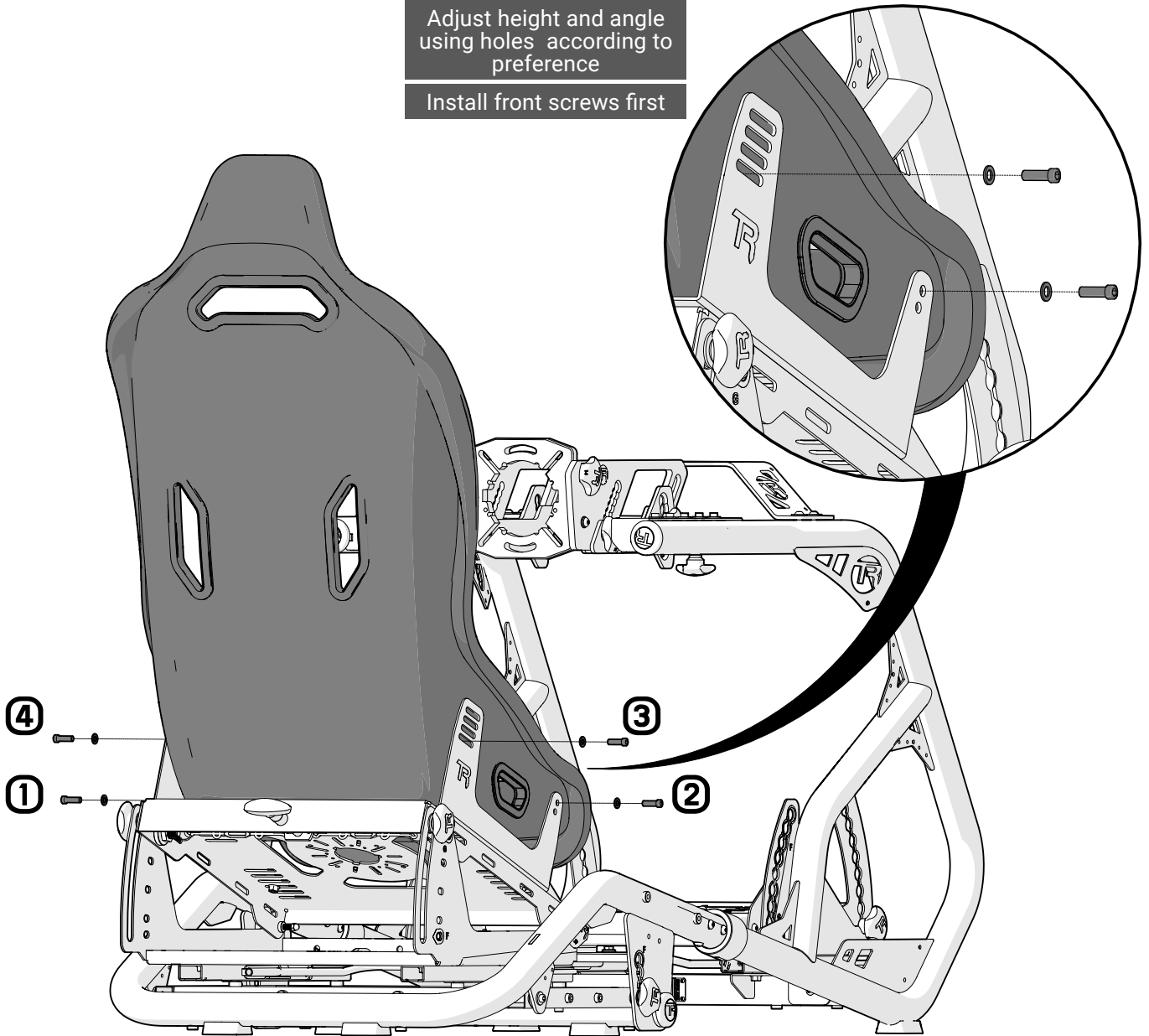

24

a

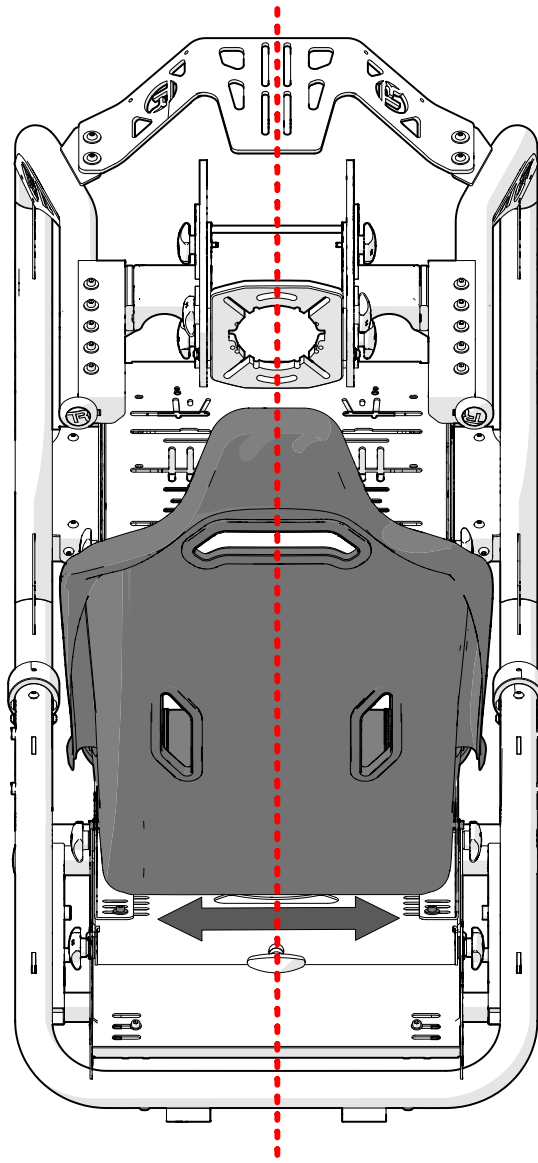

Sit in seat and center by aligning your line of sight with the center of the rig

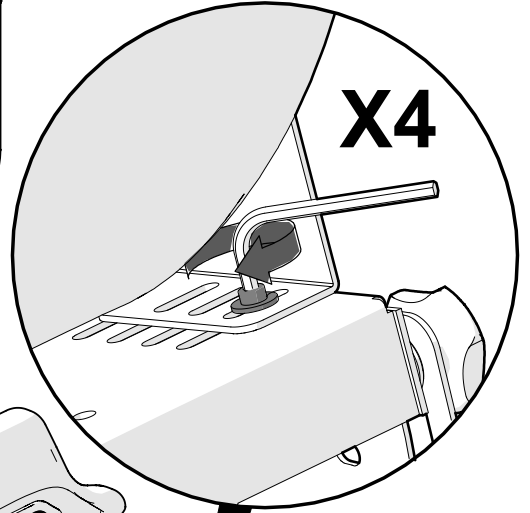
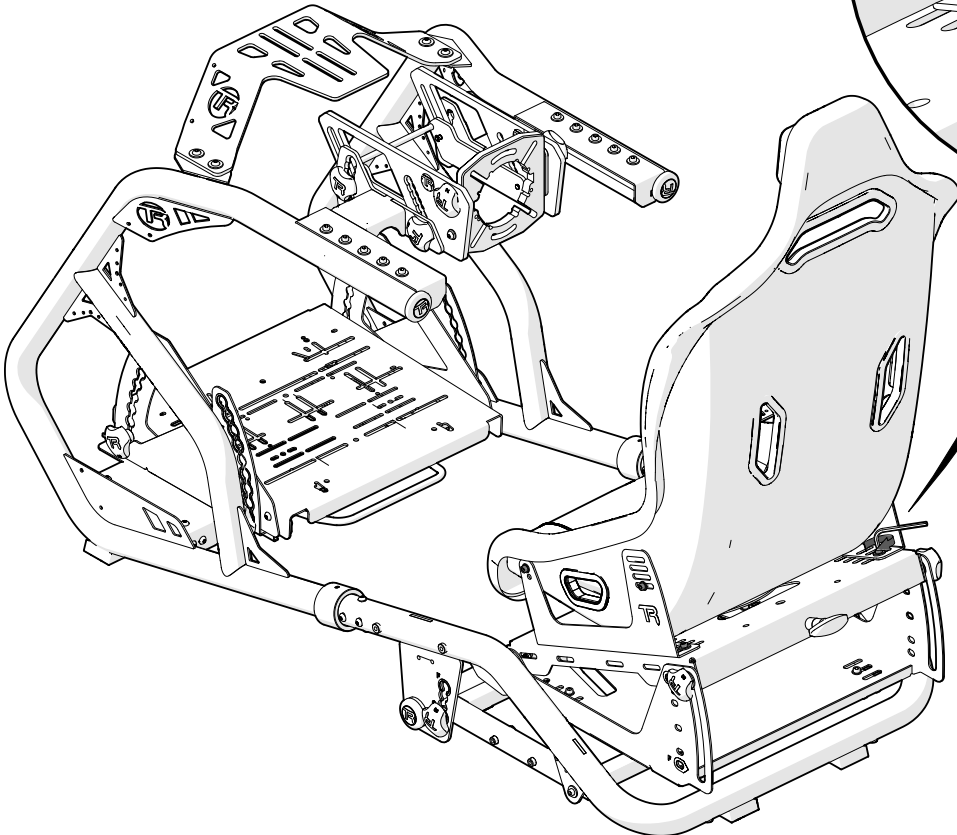

b

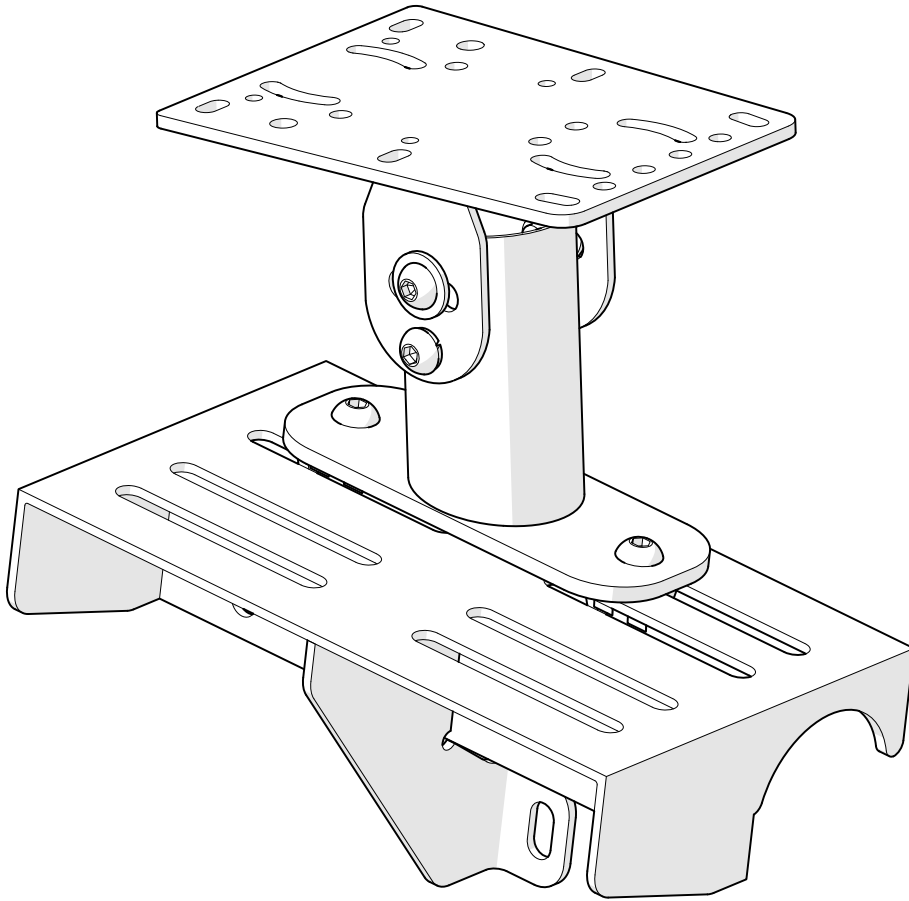

Once centered, tighten all screws to fix seat in place

OPTIONAL: TRX Shifter Mount



Part #	Image	Description	QTY	Check
BOX #: TR-TR8-SING				
TRX-GLA		TRX Shifter Mount	4	
SH-M8-16		SCREW (HEX), M8x16mm	3	
WF-M8		WASHER (FLAT), M8	3	

* **NOTE:** Extra hardware may be included as spare parts

TRX-GLA

25



TRX-GLA x1



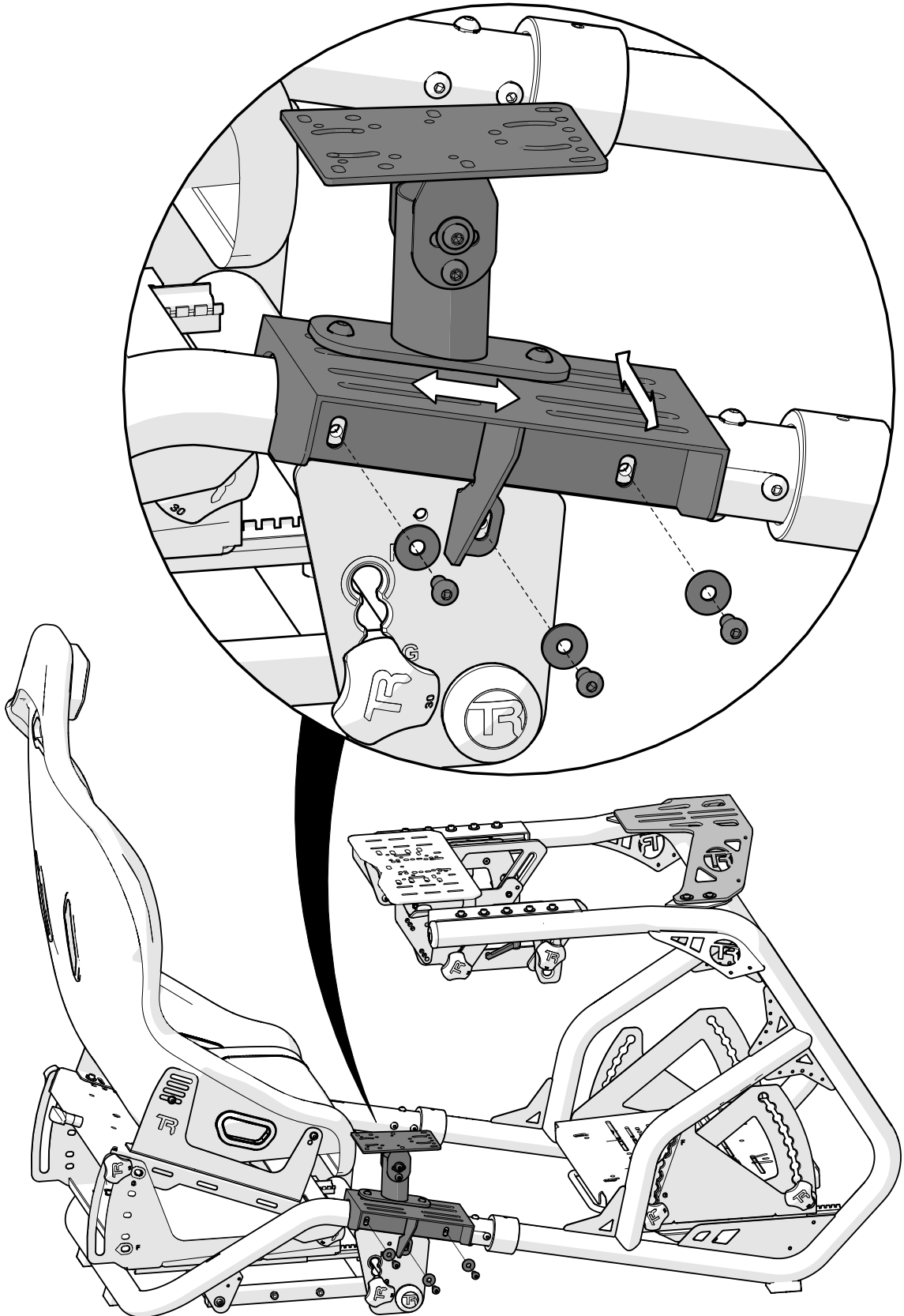



NOTE: Some screws and washers com pre-installed. These will be part of the parts list and will need to be removed and reattached according to the instructions.

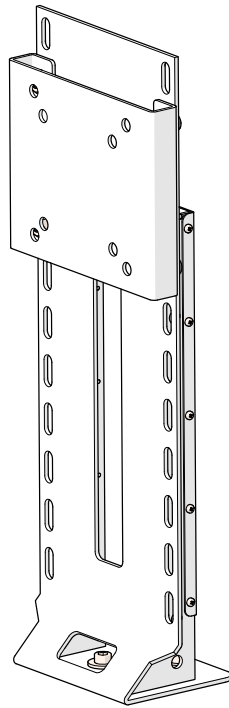

OPTIONAL: TRX Monitor Stand

Version A



Part #	Image	Description	QTY	Check
BOX #: TR-TR8-SING				
SH-M8-16		Screw (Hex), M8x16	4	
SH-M8-10		Screw (Hex), M8x10	4	
WF-M8		Washer (Flat), M8	4	
NF-M8		Nut (Flange), M8	4	
BM-IS		Integrated Single Monitor Mount	1	
VM-SIN-01		VESA Mount	1	

* **NOTE:** Extra hardware may be included as spare parts

TR-TRX-SING

26

OPTIONAL STEP: If a monitor position closer to the driver is desired in the Formula position, the monitor strut can be moved forward and mounted to the accessories mounting location on the frame.

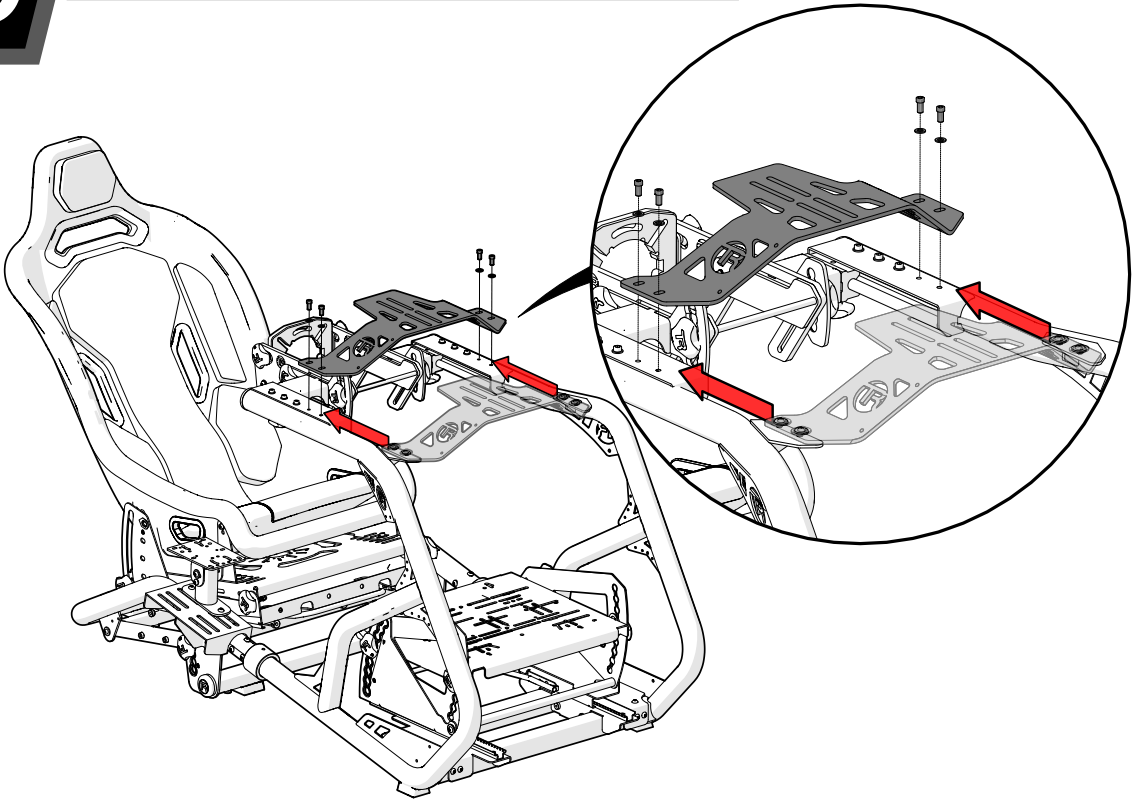

27



SH-M8-16 x4



WF-M8 x8



NF-M8 x4



BM-IS x1

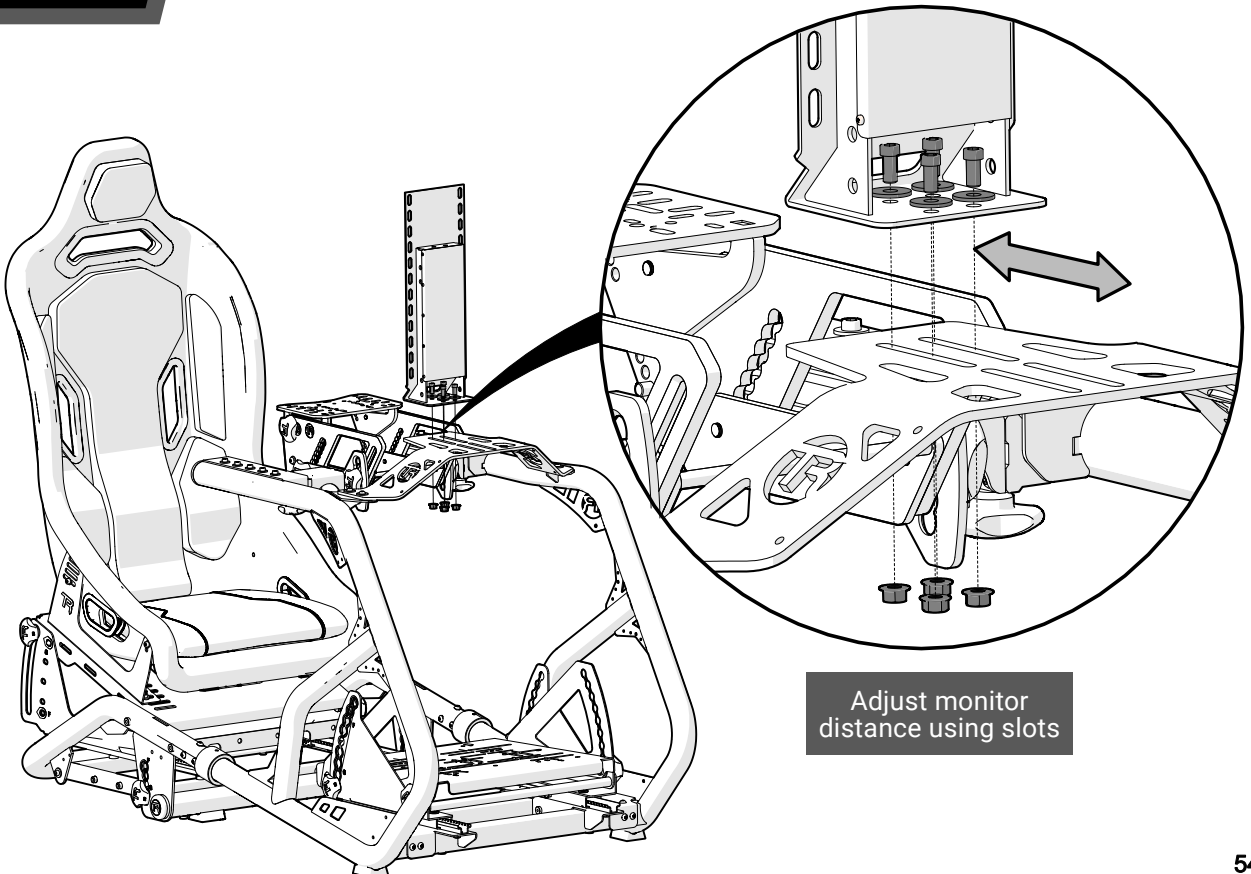

Adjust monitor distance using slots

28



VM-SIN-01 x1

NOTE: Due to the large variety of spacers and screws, TR may not include mounting hardware. When adding mounting screws ensure that the screw is an appropriate size or else you may damage your monitor.

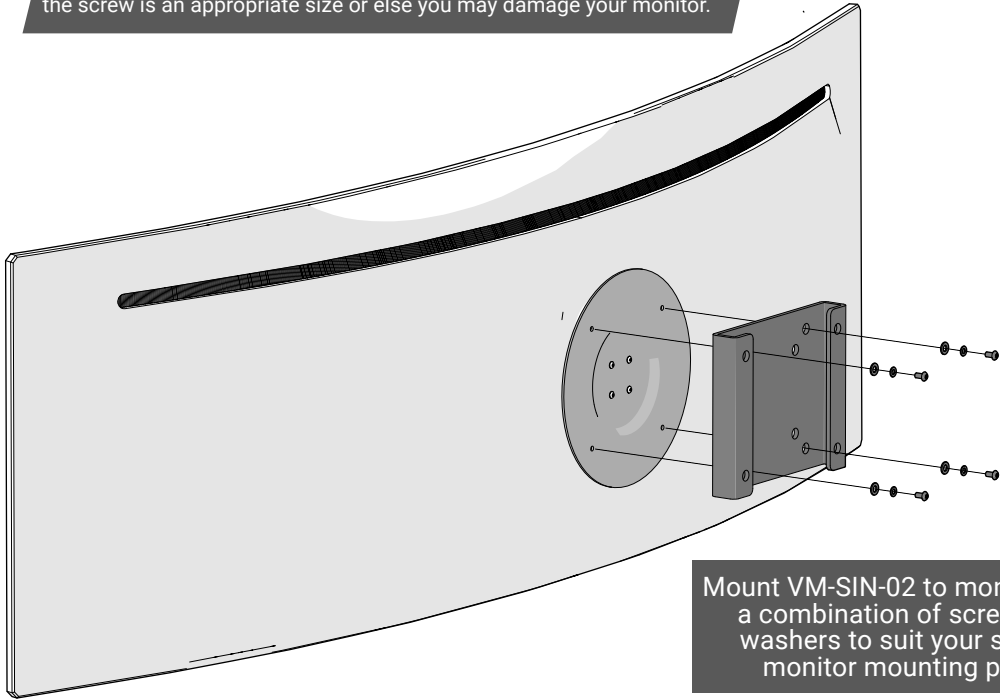

Mount VM-SIN-02 to monitor using a combination of screws and washers to suit your specific monitor mounting points

29



M8x10mm

SH-M8-10 x4

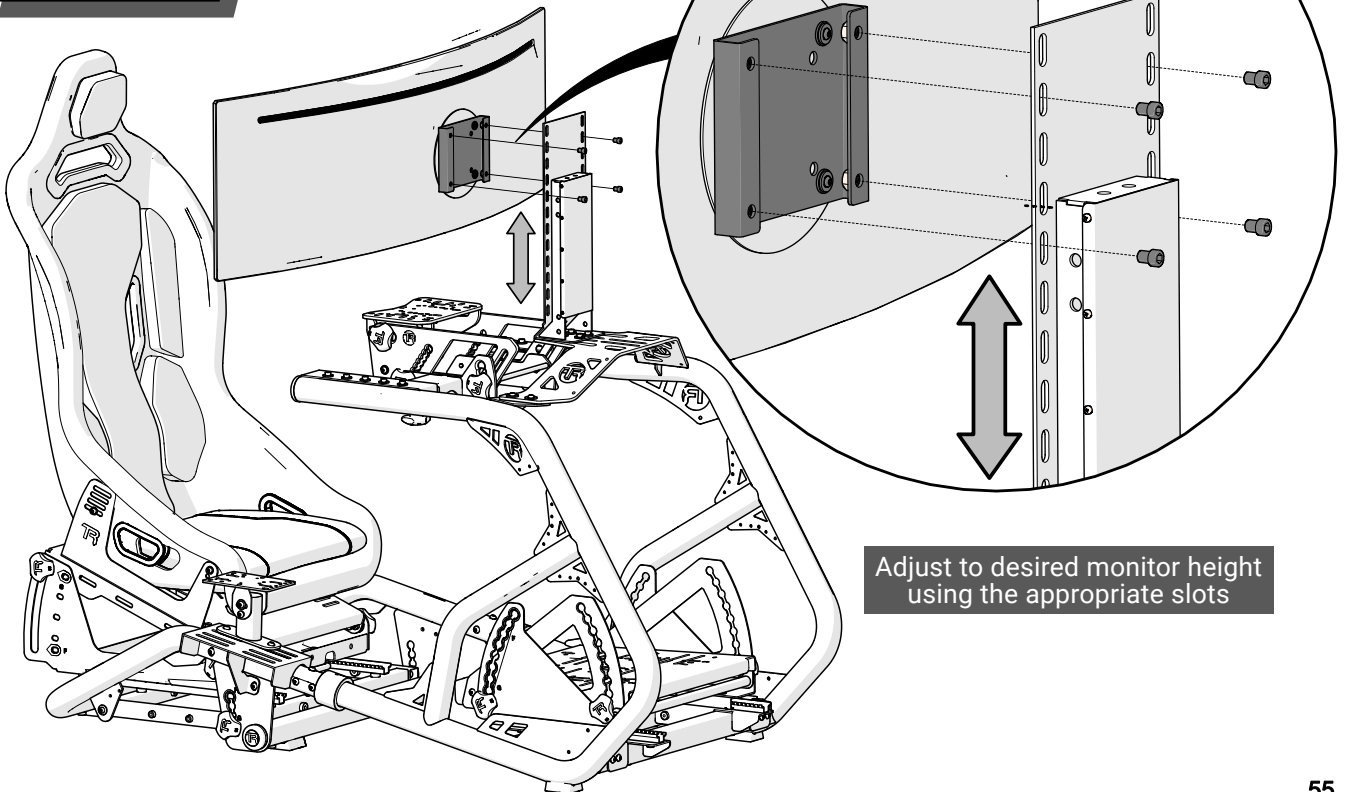





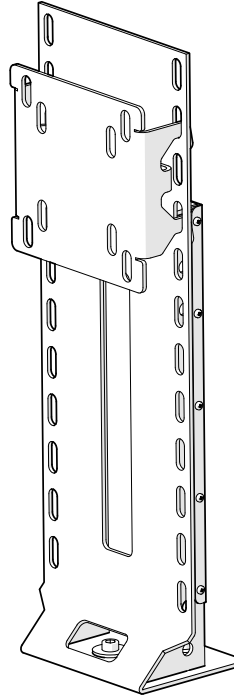

Adjust to desired monitor height using the appropriate slots

OPTIONAL: TRX Monitor Stand

Version B



Part #	Image	Description	QTY	Check
BOX #: TR-TR8-SING				
SH-M8-16		Screw (Hex), M8x16	4	
SH-M8-10		Screw (Hex), M8x10	4	
WF-M8		Washer (Flat), M8	4	
NF-M8		Nut (Flange), M8	4	
BM-IS		Integrated Single Monitor Mount	1	
VM-SIN-02		VESA Mount	1	

* **NOTE:** Extra hardware may be included as spare parts

TR-TRX-SING



TRAK RACER

Published 2023-10-10

26

OPTIONAL STEP: If a monitor position closer to the driver is desired in the Formula position, the monitor strut can be moved forward and mounted to the accessories mounting location on the frame.

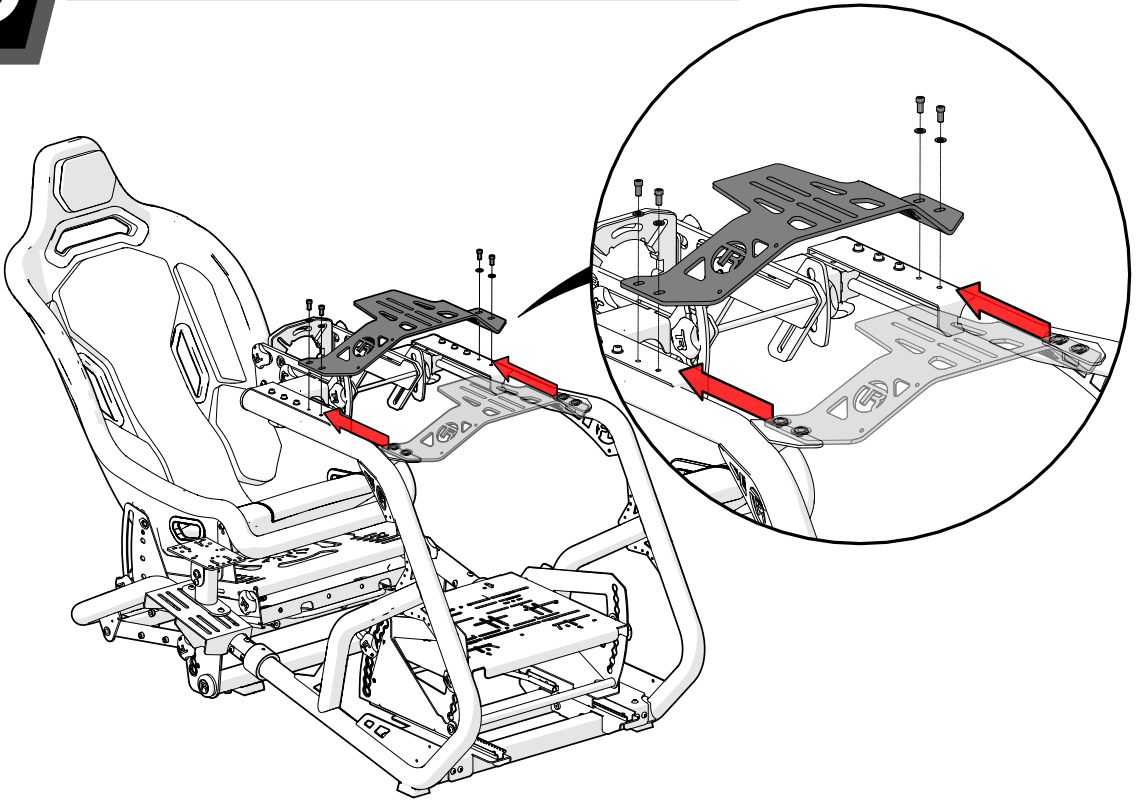

27



SH-M8-16 x4



WF-M8 x8



NF-M8 x4



BM-IS x1

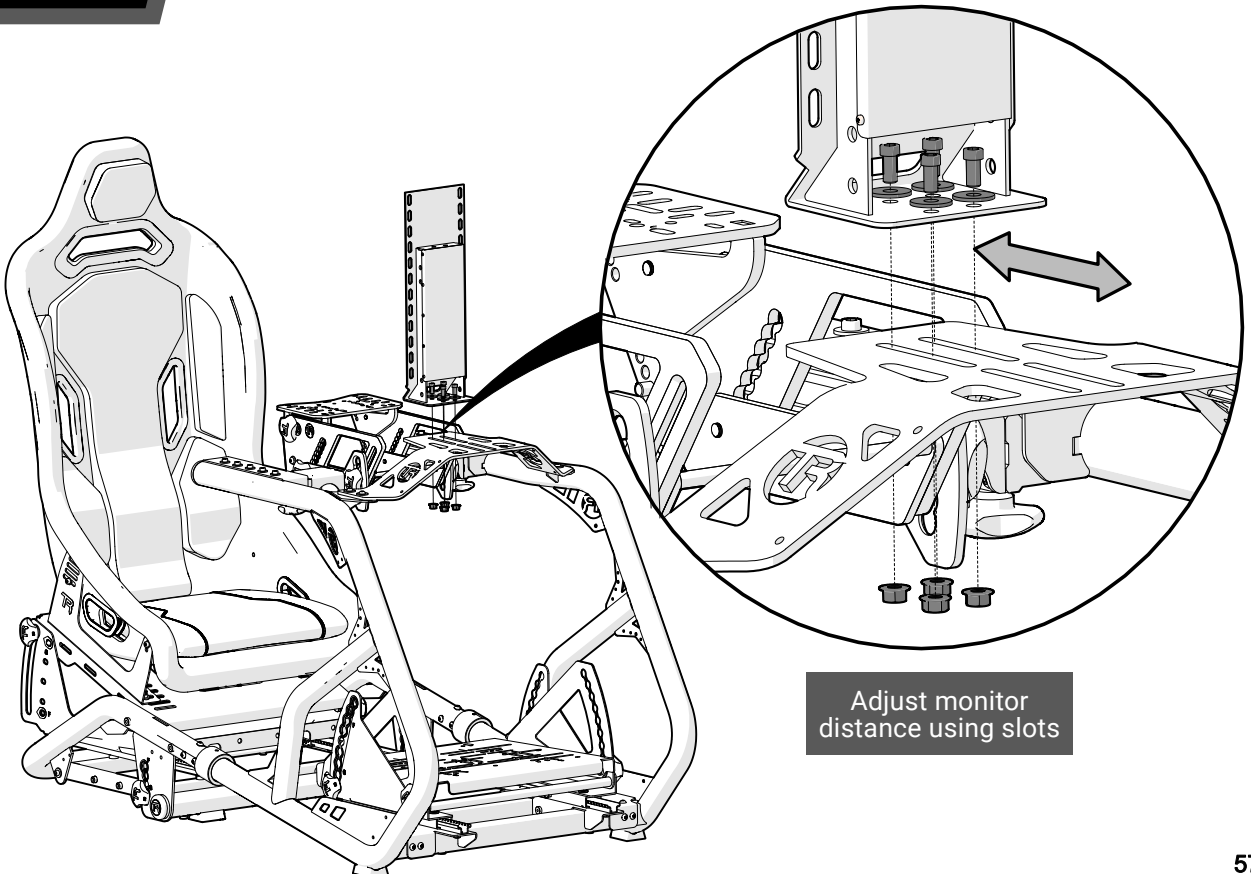

Adjust monitor distance using slots

28

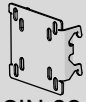

VM-SIN-02 x1

NOTE: Due to the large variety of spacers and screws, TR may not include mounting hardware. When adding mounting screws ensure that the screw is an appropriate size or else you may damage your monitor.

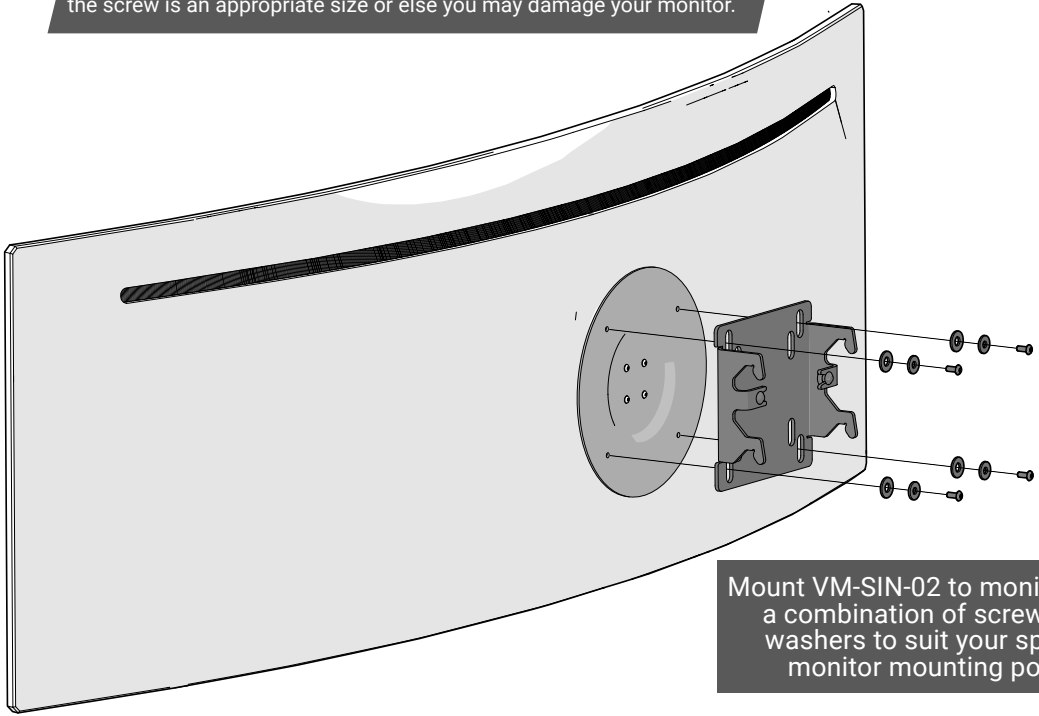

Mount VM-SIN-02 to monitor using a combination of screws and washers to suit your specific monitor mounting points

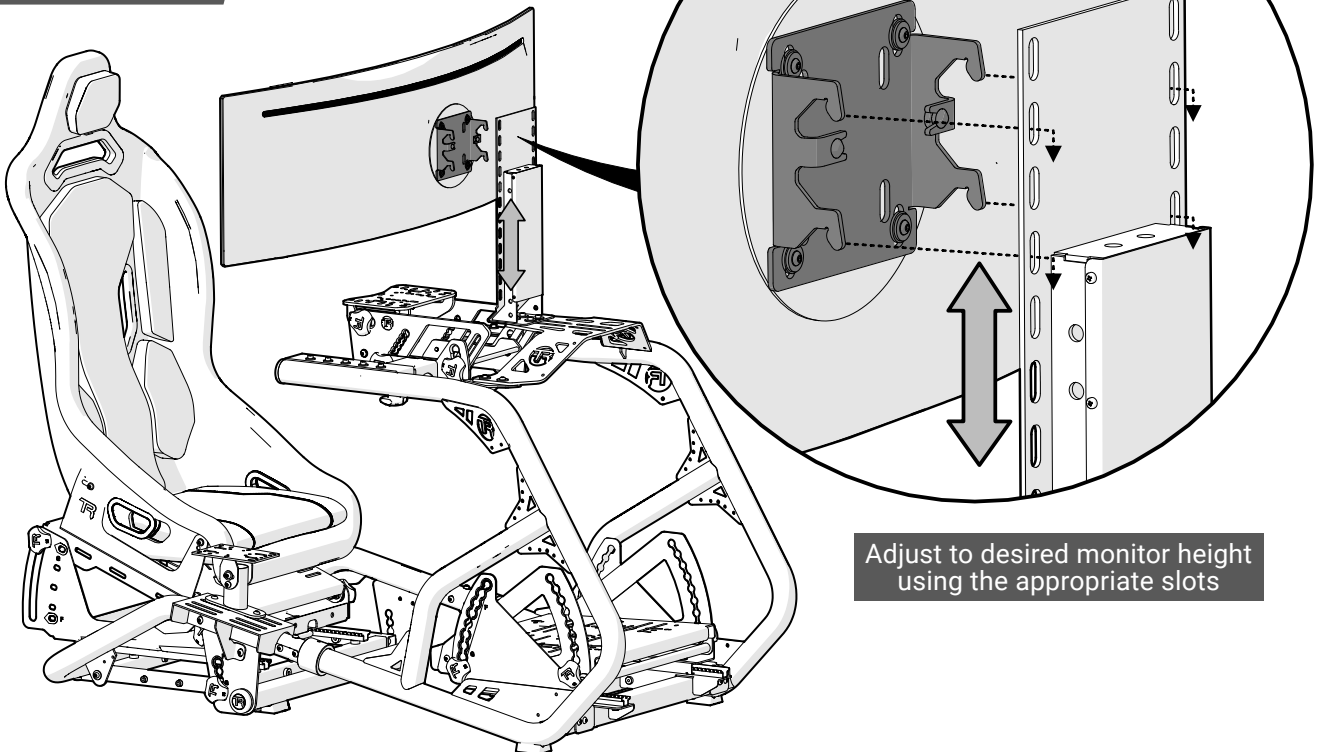

29

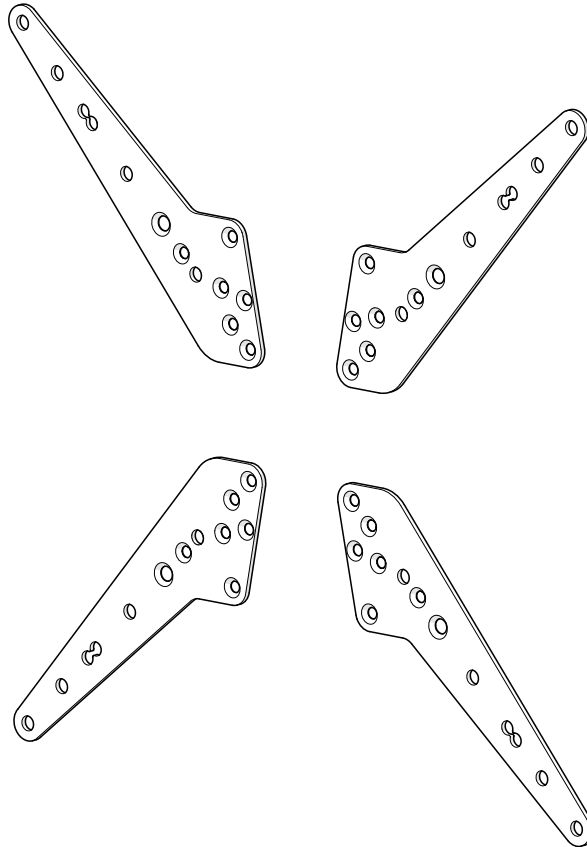

Adjust to desired monitor height using the appropriate slots

OPTIONAL: VESA MOUNT EXTENSION ARMS

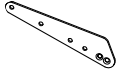
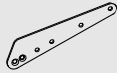
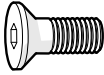

Part #	Description	QTY	Check
BOX #: TR-80B			
VM-02-A	 VESA Extension A	2	
VM-02-B	 VESA Extension B	2	
SF-M8-16	 Screw (Flat), M8x16	8	
NL-M6	 Nut (Locking), M6	8	

TR-80B

30



M6x16mm

SF-M6-16 x8



NL-M6 x8

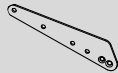

VM-02-A x2

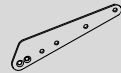

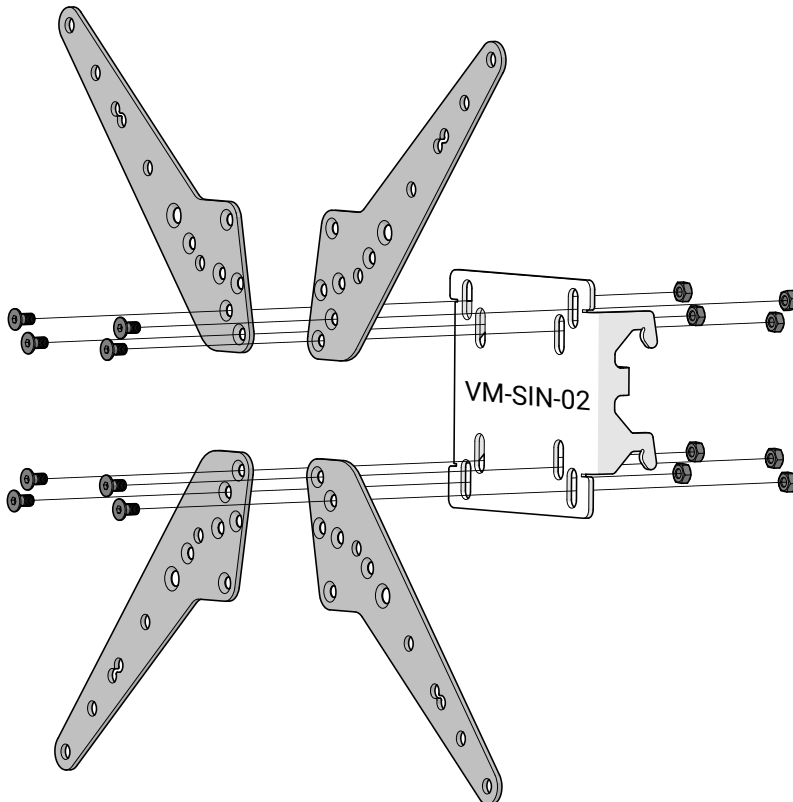
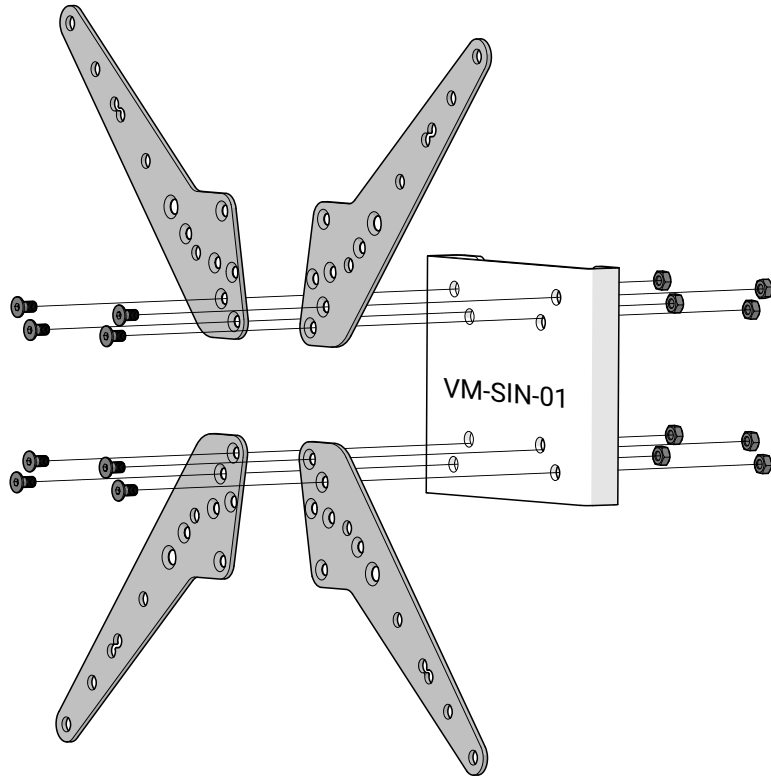

VM-02-B x2

NOTE: For use with monitors with mounting hole spacing larger than 100mm

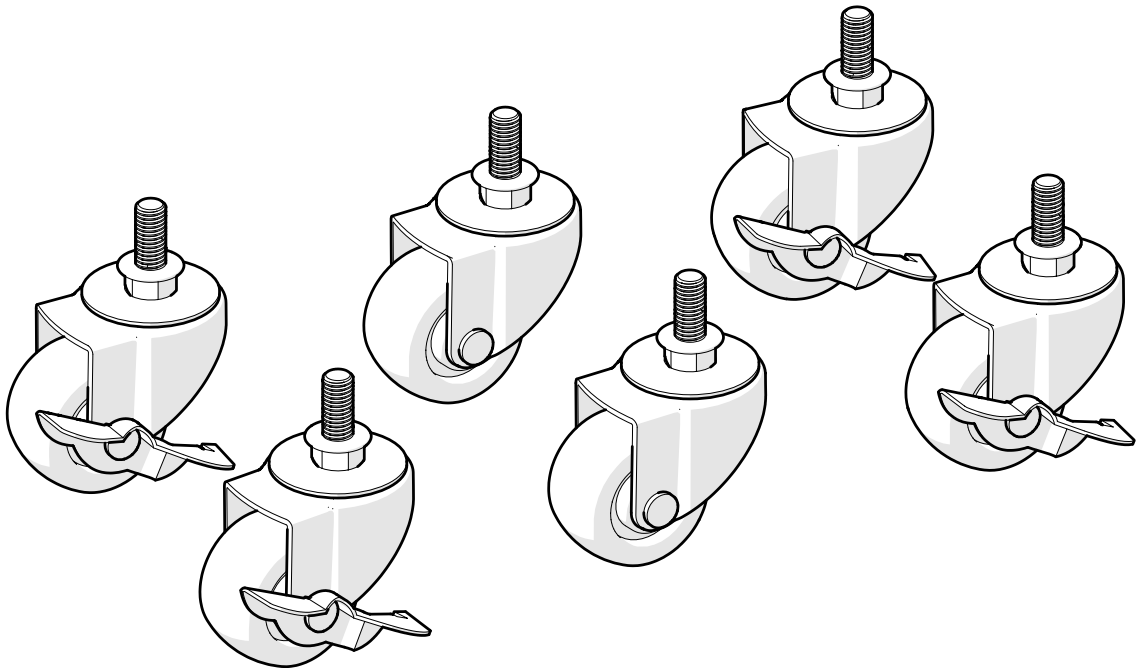

OPTIONAL: LOCKING WHEELS



Part #	Description	QTY	Check
BOX #: TR-WKIT-2			
CA-WKIT-F	 Caster Wheels, Free	2	
CA-WKIT-L	 Caster Wheels, Locking	2	

* **NOTE:** Extra hardware may be included as spare parts

TR-WKIT-2

31



CA-WKIT-F x2



CA-WKIT-L x4



NF-M8 x4

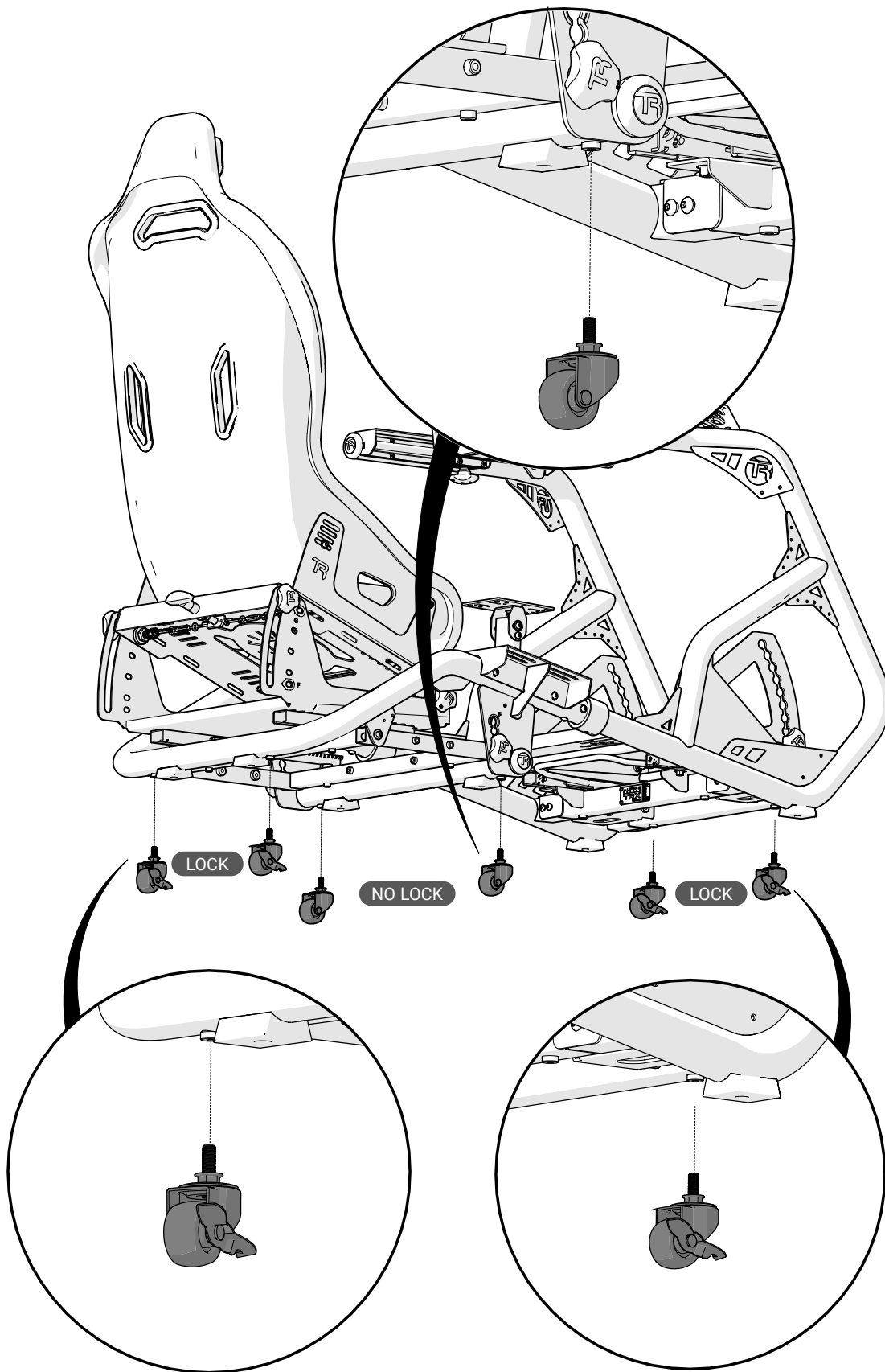

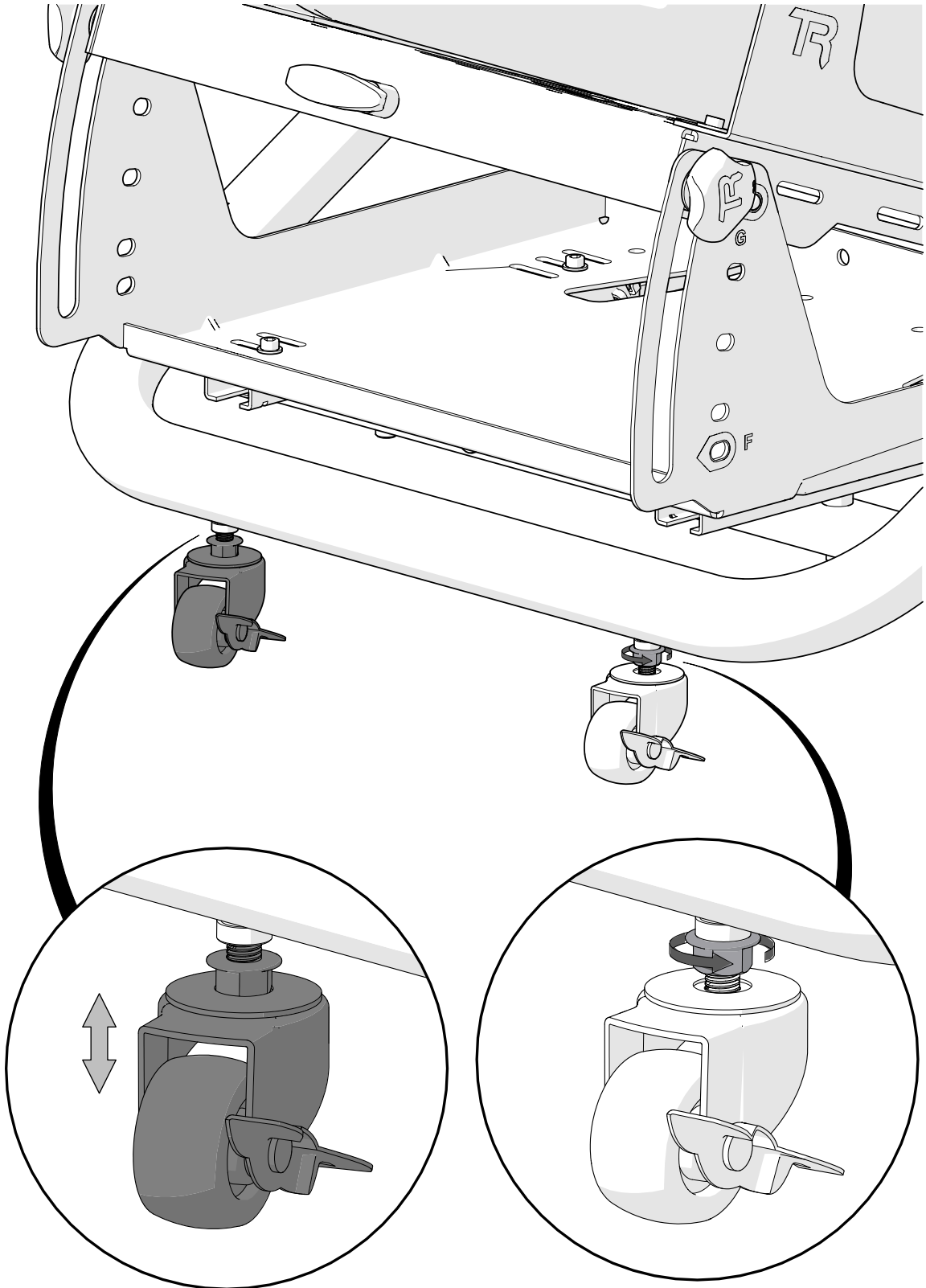

a Adjust height and level rig

b Tighten nut

FINISHED



Share your build online and tag us to be featured!



@trakracer



@trakracer



@trak_racer